



■ Features :

- AC input range selected by switch
- Protections: Short circuit/ Over voltage/Over load/ Over temp.
- High reliability/ Low ripple noise
- Built-in remote sense function
- Built-in remote ON-OFF control
- With parallel function
- Can adjust from 20~100% output voltage by external control 1-5V
- Forced air cooling by built-in DC fan
- Case coating with paint
- 2 years warranty



SPECIFICATION

ORDER NO.	SCN-600-05	SCN-600-12	SCN-600-15	SCN-600-18	SCN-600-24	SCN-600-48	
OUTPUT	SAFETY MODEL NO.	600S-N005	600S-N012	600S-N015	600S-N018	600S-N024	600S-N048
	DC VOLTAGE	5V	12V	15V	18V	24V	48V
	RATED CURRENT	100A	50A	40A	33A	25A	12A
	CURRENT RANGE	0 ~ 100A	0 ~ 50A	0 ~ 40A	0 ~ 33A	0 ~ 25A	0 ~ 12A
	RATED POWER	500W	600W	600W	600W	600W	600W
	RIPPLE & NOISE (max.) Note.2	100mVp-p	120mVp-p	150mVp-p	180mVp-p	240mVp-p	480mVp-p
	VOLTAGE ADJ. RANGE	±5.0% typical adjustment by potentiometer		20~100% adjustment by 1~5VDC external control			
	VOLTAGE TOLERANCE Note.3	±1.5%	±1.0%	±1.0%	±1.0%	±1.0%	±1.0%
	LINE REGULATION	±0.5%	±0.5%	±0.5%	±0.5%	±0.5%	±0.5%
	LOAD REGULATION	±1.0%	±0.5%	±0.5%	±0.5%	±0.5%	±0.5%
SETUP, RISE, HOLD TIME	800ms, 50ms, 16ms at full load						
INPUT	VOLTAGE RANGE	90 ~ 130VAC / 180~260VAC selected by switch, 260~370VDC					
	FREQUENCY RANGE	47~63Hz					
	EFFICIENCY (Typ.)	77%	80%	81%	82%	85%	87%
	AC CURRENT	11A / 115VAC 7.0A / 230VAC					
	INRUSH CURRENT (max.)	60A / 230VAC					
	LEAKAGE CURRENT	3.5mA / 240VAC					
PROTECTION	OVER LOAD	101~115%	110~135% rated output power				
		Protection type : Current limiting, delay shut down o/p voltage, re-power on to recover					
	OVER VOLTAGE	110~135% follow to output set up point					
	Protection type : Shut down o/p voltage, re-power on to recover						
OVER TEMPERATURE	>100°C / measure by heat sink, near transformer						
	Protection type : Shut down o/p voltage, re-power on to recover						
ENVIRONMENT	WORKING TEMP.	-10~+65°C (Refer to output load derating curve)					
	WORKING HUMIDITY	20%~90% RH non-condensing					
	STORAGE TEMP., HUMIDITY	-20~+85°C, 10~95% RH					
	TEMP. COEFFICIENT	±0.04% / °C (0~50°C)					
	VIBRATION	10~200Hz, 2G 10min./1cycle, period for 60min. each along X, Y, Z axes					
SAFETY & EMC (Note. 4)	SAFETY STANDARDS	UL1950, CSA22.2, IEC60950 Approved					
	WITHSTAND VOLTAGE	I/P-O/P, I/P-FG:1500VAC					
	ISOLATION RESISTANCE	I/P-O/P, I/P-FG, 100M Ohms / 500VDC					
	EMI CONDUCTION & RADIATION	Compliance to FCC part 15 class A					
	HARMONIC CURRENT	----					
	EMS IMMUNITY	----					
OTHERS	MTBF	120khrs min. MIL-HDBK-217F (25°C)					
	DIMENSION	291*132*68mm (L*W*H)					
	PACKING	2.3kg; 8pcs/ 24kg/ CARTON					
	SPECIAL FUNCTION	DC voltage adj., Remote sensing, remote control, parallel operation (refer to terminal instruction manual)					
NOTE	<p>1.All parameters are specified at 230VAC input, rated load, 25°C 70% RH. Ambient.</p> <p>2.Tolerance: includes set up tolerance, line regulation, load regulation.</p> <p>3.Ripple & noise are measured at 20MHz by using a 12" twisted pair terminated with a 0.1uf & 47uf capacitor.</p> <p>4.The power supply is considered a component which will be installed into a final equipment. The final equipment must be re-confirmed that it still meets EMC directives.</p>						

Mechanical Specification

Unit:mm

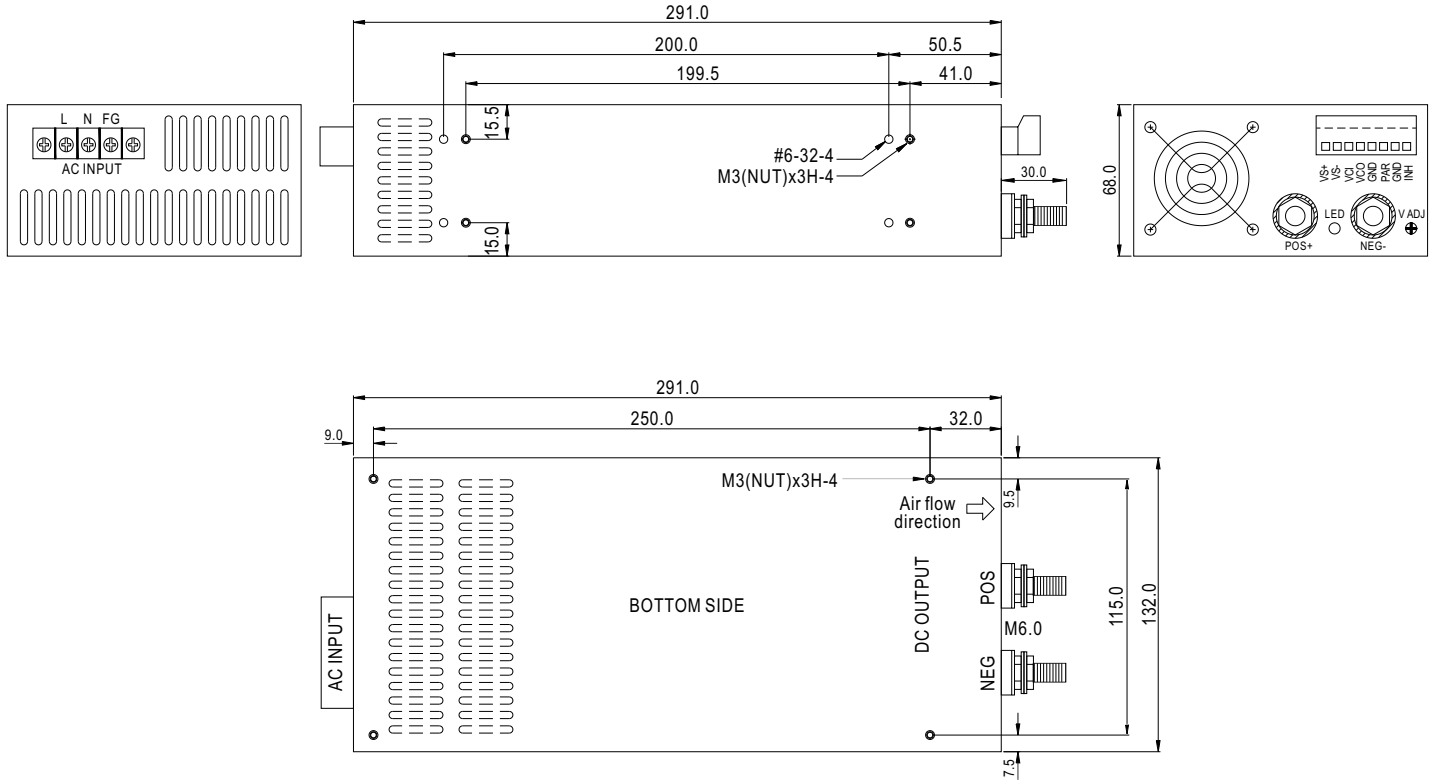

Derating Curve

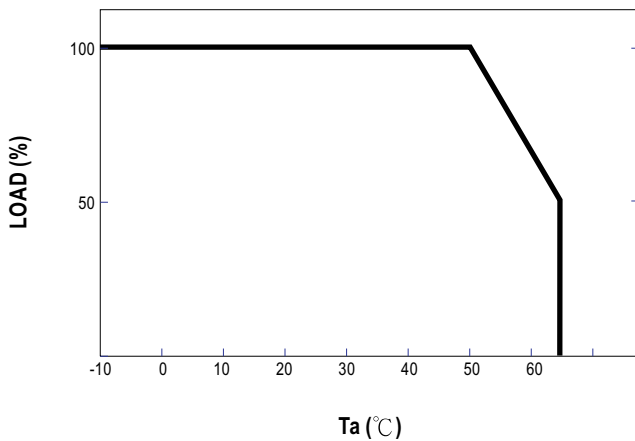

External DC Control VS Output Voltage

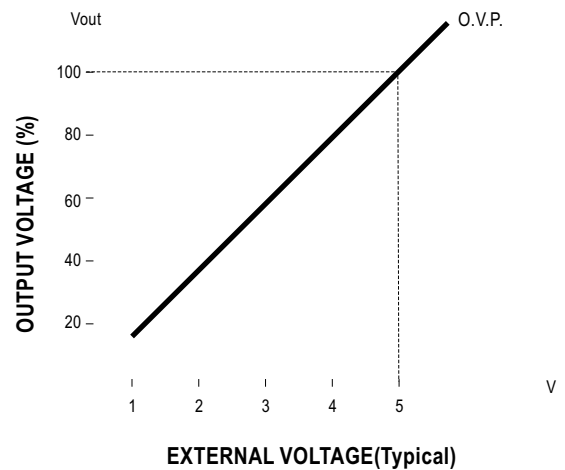

Control terminal instruction manual

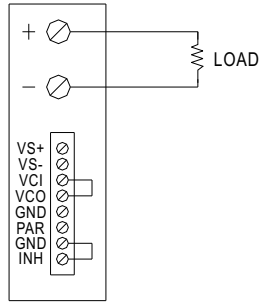

USING INTERNAL VOLTAGE CONTROL

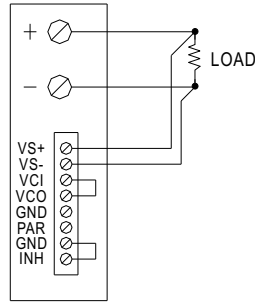

REMOTE SENSING

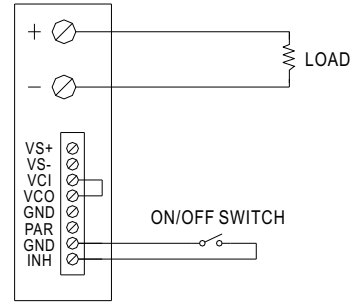

ON/OFF CONTROL BY SWITCH

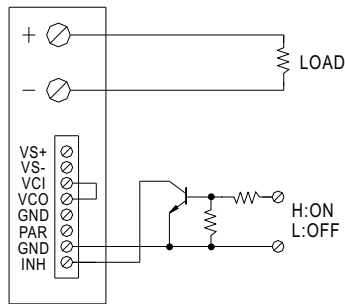

ON/OFF CONTROL BY TRANSISTOR

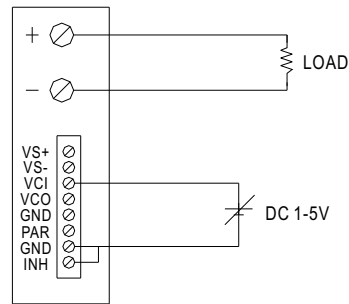

OUTPUT VOLTAGE ADJUST WITH DC 1-5V

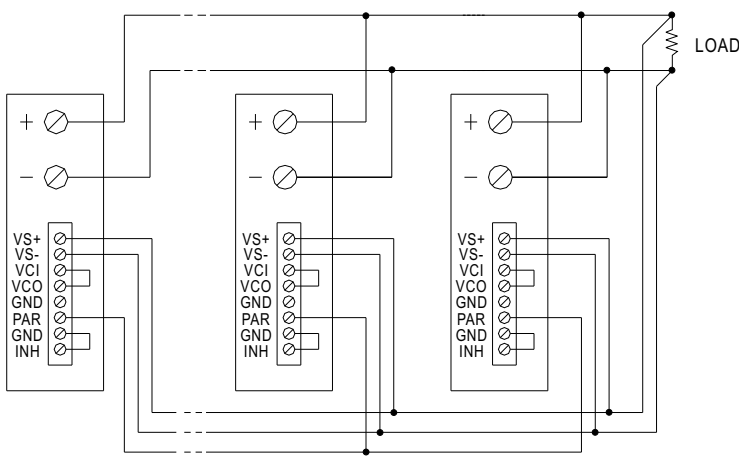

PARALLEL OPERATION WITH REMOTE SENSING

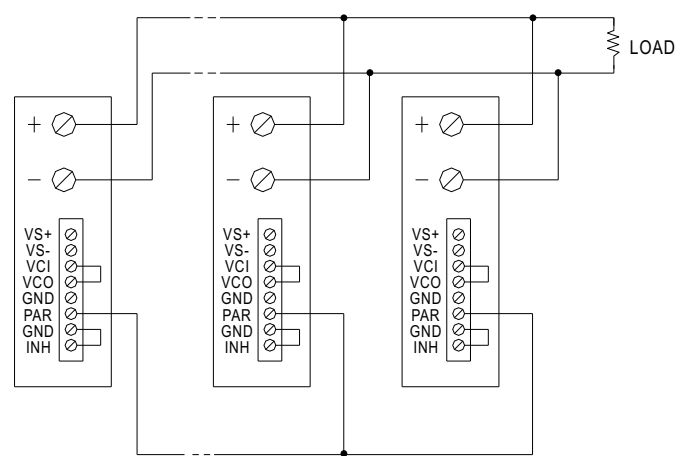

PARALLEL OPERATION