

HIGH TORQUE HYBRID STEPPING MOTOR SPECIFICATIONS

General specifications		Electrical specifications	
Step Angle (°)	0.9	Rated Voltage (V)	4
Temperature Rise (°C)	80 Max (rated current, 2 phase on)	Rated Current (A)	1.2
Ambient temperature (°C)	-20~+50	Resistance Per Phase ($\pm 10\%$)	3.3 (25°C)
Number of Phase	2	Inductance Per Phase ($\pm 20\%$)	4
Insulation Resistance	100M Ω , Min (500VDC)	Holding Torque (Kg.cm)	3.17
Insulation Class	Class B	Detent Torque (g.cm)	250
Max.radial force (N)	28 (20mm from the flange)	Rotor Inertia (g.cm ²)	68
Max.axial force (N)	10	Weight (Kg)	0.365

● Pull out torque curve:

VOLTAGE: 24VDC, CONSTANT CURRENT: 1.2A, HALF STEP

● Wiring Diagram:

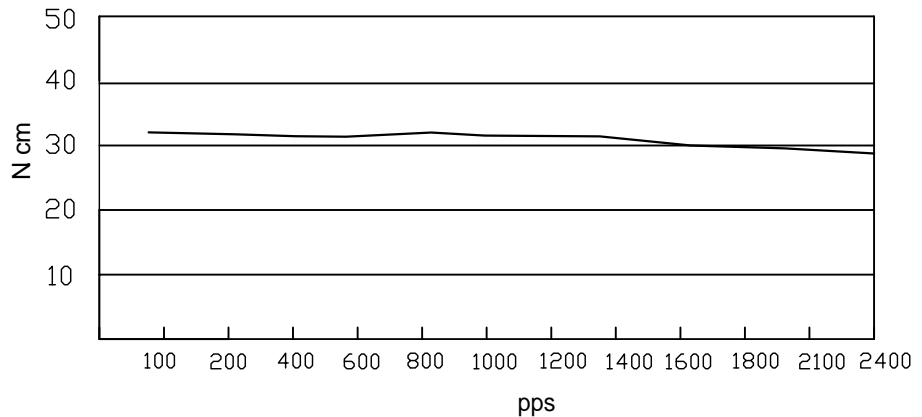
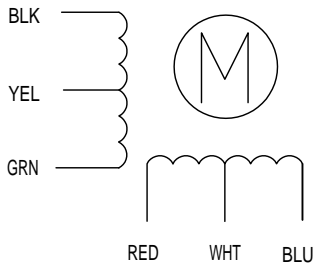

● Dimensions:
(unit=mm)

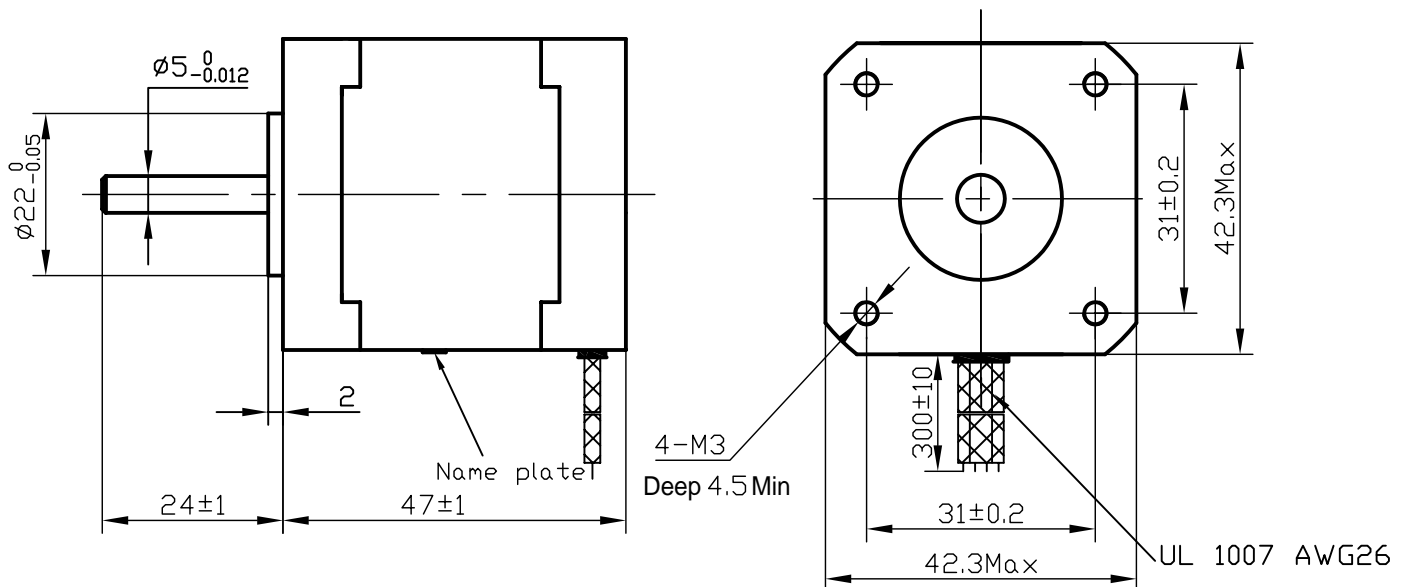

△					SY42STH47-1206MA	TECHNICAL CONDITIONS
△						
REV	REVISIONS	DESCRIPTION	BY	DATE	CHANGZHOU SONGYANG MACHINERY & ELECTRONICS NEW TECHNIC INSTITUTE	050047000
DRAW	孔祥振	2011.01.14				
CHECK						
APPROVE						

This document was created with Win2PDF available at <http://www.daneprairie.com>.
The unregistered version of Win2PDF is for evaluation or non-commercial use only.