

# HIGH TORQUE HYBRID STEPPING MOTOR SPECIFICATIONS

General specifications		Electrical specifications	
Step Angle (°)	1.8	Rated Voltage (V)	2.8
Temperature Rise (°C)	80 Max (rated current, 2 phase on)	Rated Current (A)	1.68
Ambient temperature (°C)	-20~+50	Resistance Per Phase ( $\pm 10\%$ )	1.65 (25°C)
Number of Phase	2	Inductance Per Phase ( $\pm 20\%$ mH)	3.2
Insulation Resistance	100M $\Omega$ , Min (500VDC)	Holding Torque (Kg.cm)	3.6
Insulation Class	Class B	Detent Torque (g.cm)	150
Max.radial force (N)	28 (20mm from the flange)	Rotor Inertia (g.cm <sup>2</sup> )	54
Max.axial force (N)	10	Weight (Kg)	0.28

● Pull out torque curve:

VOLTAGE: 28VDC, CONSTANT CURRENT: 1.68A, HALF STEP

● Wiring Diagram:

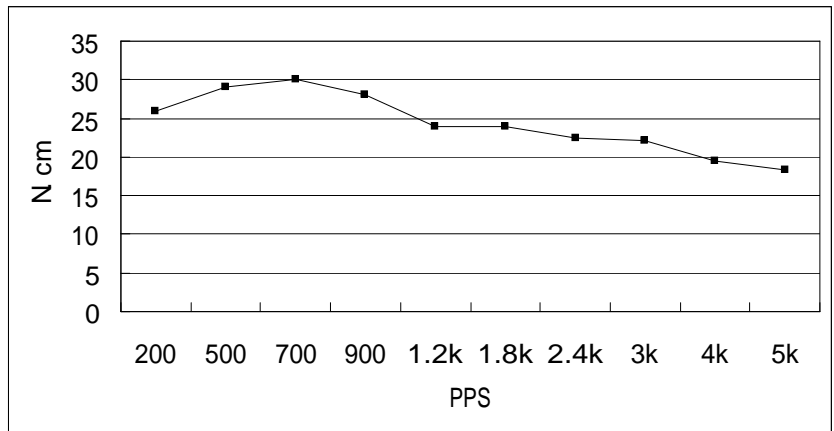
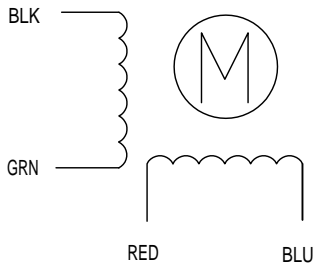

● Dimensions:  
(unit=mm)

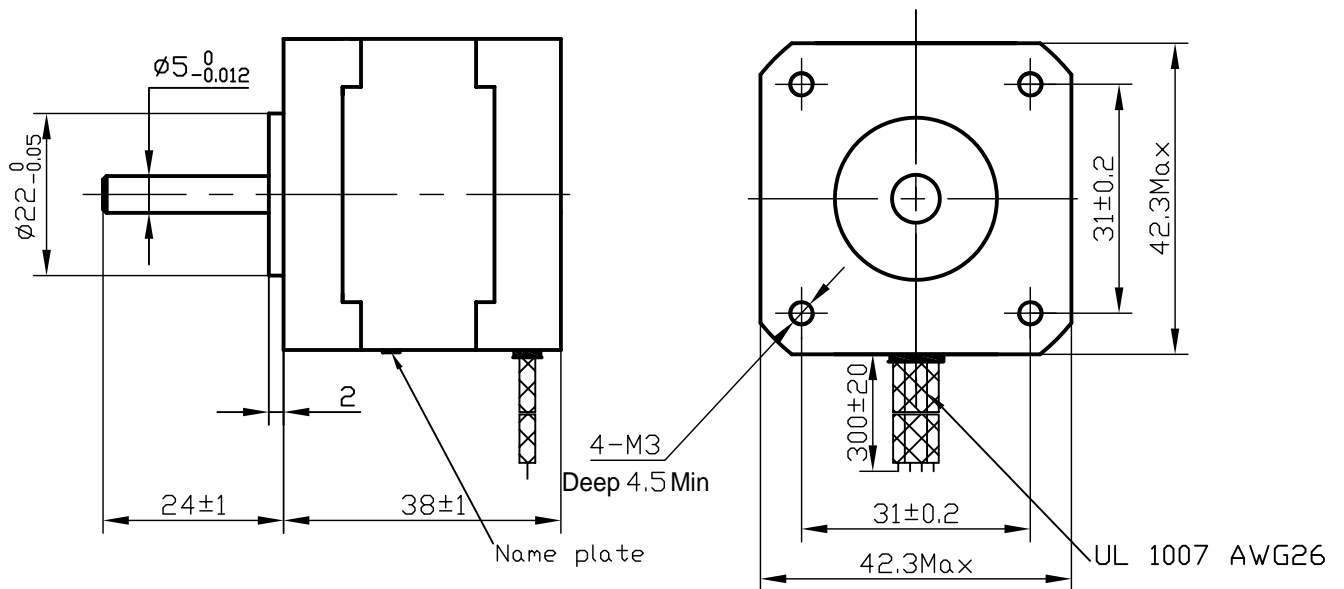

△					SY42STH38-1684A	TECHNICAL CONDITIONS
△						
REV	REVISIONS	DESCRIPTION	BY	DATE	CHANGZHOU SONGYANG MACHINERY & ELECTRONICS NEW TECHNIC INSTITUTE	060038003
DRAW	袁卫国					
CHECK						
APPROVE						