

REVISION RECORD

REV	ECN	DESCRIPTION	DRFT	DATE

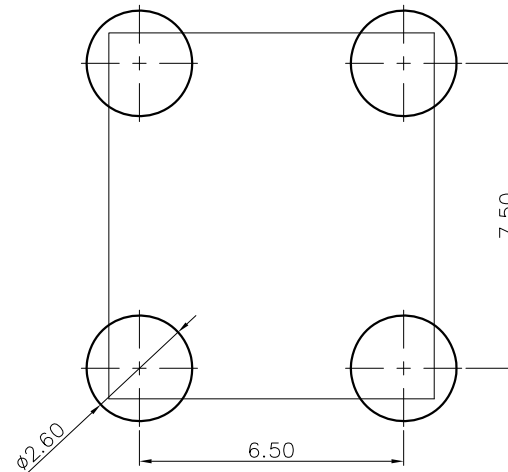

PCB LAYOUT

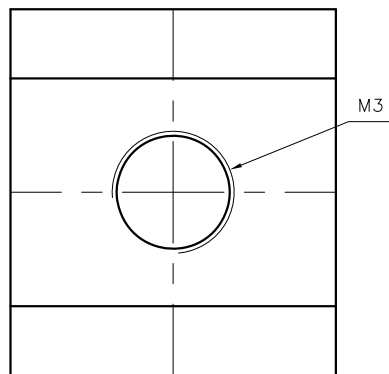
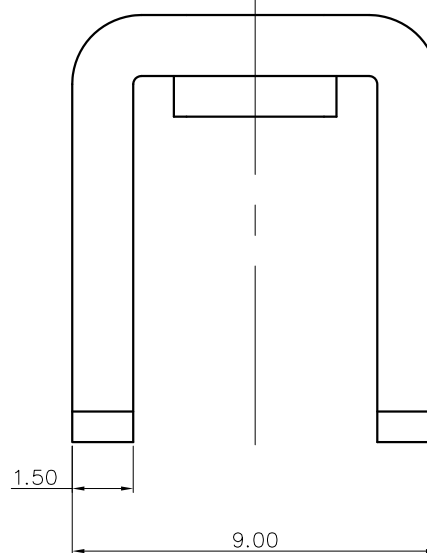
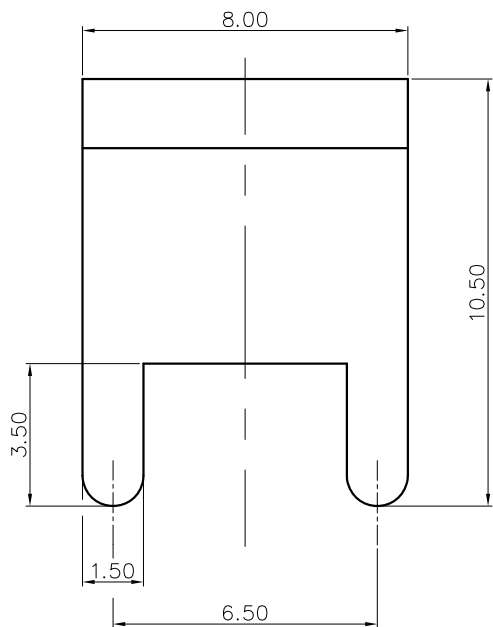

NOTES:

- 1.Dimension shall be interpreted per ASME Y14.5-2009
- 2.Torque value : M3 , 4.43Lb.in
- 3.Undimensioned tolerances:

Pitch range in mm			Nominal dimension range in mm					0.1/10
TO	Over TO	Over TO	TO	Over TO	Over TO	Over TO		
6	10	24	30	60	100	150	$\pm 2'$	
± 0.15	± 0.20	± 0.30	± 0.30	± 0.50	± 0.70	± 1.00	± 1.30	

4.RoHS Compliance

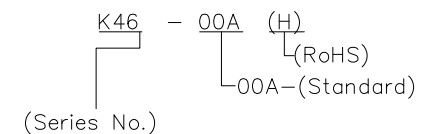

DETACHED LISTS	PART NO.:	/			
	APPD:	/			
	CHKD:	/			
	DRFT:	/			
		 THIRD ANGLE PROJECTION		 DO NOT SCALE DRAWING	
		DRAWING NO.:		REV	DO
		/		SHEET	1/1
		MM (INCH)		SCALE	1:1

宁波高松电子有限公司
 NINGBO DEGSON ELECTRICAL CO., LTD

K46-00A(H)

TITLE: CUSTOMER DRAWING

DRAWING NO.:

MM (INCH)

REV

DO

SHEET

1/1

SCALE

1:1

H
G
F
E
D
C
B
A

H
G
F
E
D
C
B
A