

REVISION RECORD			
REV/ECO	DESCRIPTION	DRFT	DATE
△	增加U刻字	CSX	03/21/07
△	品名、料号增加环保标识“(H)”	YeJ	12/08/07

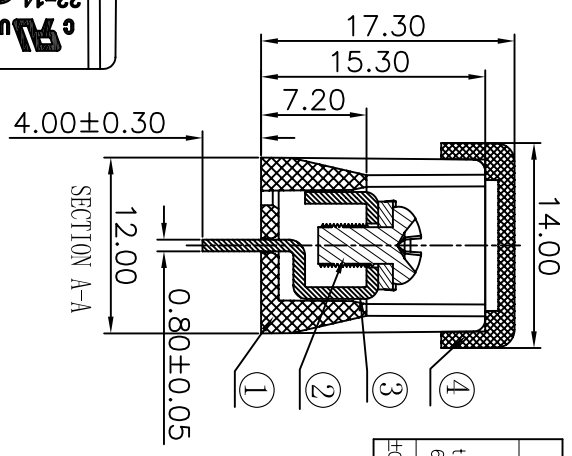
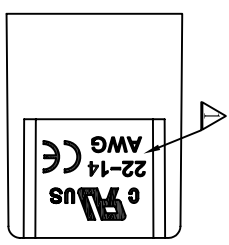
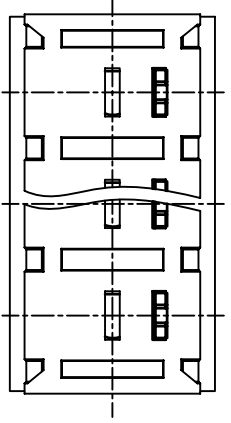
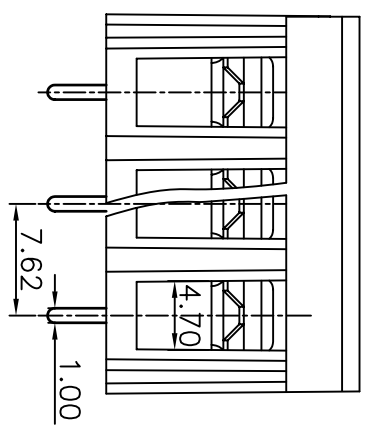
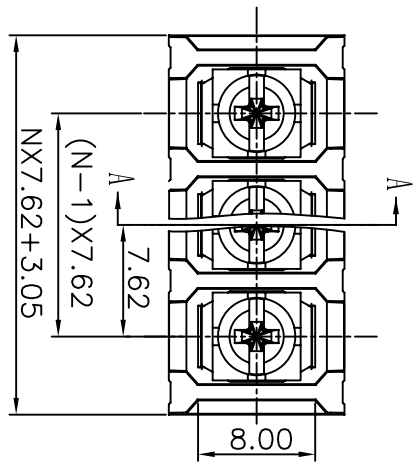

Pitch range in mm	Nominal dimension range in mm	
over 6	over 30	over 60
to 10	to 100	to 150
to 24	to 300	to 1500
to 60	to 1000	to 15000
to 150	to 3000	to 150000
to 300	to 10000	to 1500000
to 600	to 30000	to 15000000
to 1200	to 100000	to 150000000
to 2400	to 300000	to 1500000000
to 4800	to 1000000	to 15000000000

- Notes:
1. Pitch: 7.62mm, Poles: 2-26P
 2. Rated current: 15A
 3. Rated voltage: 300V
 4. Operation temperatures: -40° C ~ +105° C
 5. Insulation Withstand Voltage: AC2000V/Min
 6. Insulation Resistance: 500MΩ /DC500V
 7. Wire Range: 22~14AWG
 8. Max. Torque Value: 5. 1kgf. cm
 9. Undimensioned Tolerances:

1	ITEM	NAME OF PART	NO. OF PART	Q'TY	MATERIAL	NOTES
1		DG28-B-本体	5006A0YXXA(H)	1	PA66+23%GF	UL94V-0
4		DG28-Cover	5006C07YXXA(H)	1	PC	
3		DG28C Pin header	5006B00010(H)	XX	Brass	
2		M3*6 (6*6) bright Screws	S000000450(H)	XX	Steel	Ni plated

DETACHED LISTS

UNIT	MIN	MAX
ANGLES ± °	±	±
ANGLES ± ' "	±	±
TOLERANCES EXCEPT AS NOTED	MM	INCH
0.1 ±	±	±
0.05 ±	±	±
0.02 ±	±	±

DEGSON 宁波高正电子有限公司
DEGSON ELECTRONICS CO., LTD.

NAME: DG28C-B-XXP-1Y-00A(H)

DRAWING NO.: DG28C-E02

SIZE: A3

4	DG28-Cover	5006C07YXXA(H)	1	PC
3	DG28C Pin header	5006B00010(H)	XX	Brass
2	M3*6 (6*6) bright Screws	S000000450(H)	XX	Steel