

EnerChip CC with Integrated Power Management

Features

- Power Manager with Charge Control
- Integrated 5µAh Solid State Battery
- Built-in Energy Storage Protection
- Temperature Compensated Charge Control
- Adjustable Switchover Voltage
- Charges EnerChip Over a Wide Supply Range
- Low Standby Power
- SMT - Lead-Free Reflow Tolerant
- Thousands of Recharge Cycles
- Low Self-Discharge
- Eco-Friendly, RoHS Compliant - tested

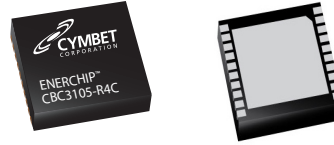

4mm x 5mm x 0.9mm DFN SMT Package

The EnerChip CC is the world's first Intelligent Thin Film Energy Storage Device. It is an integrated solution that provides backup energy storage and power management for systems requiring power bridging and/or secondary power. A single EnerChip CC can charge up to 10 additional EnerChips connected in parallel.

Applications

- **Standby supply** for non-volatile SRAM, Real-time clocks, controllers, supply supervisors, and other system-critical components.
- **Wireless sensors and RFID tags** and other powered, low duty cycle applications.
- **Localized power source** to keep microcontrollers and other devices alert in standby mode.
- **Power bridging** to provide back-up power to system during exchange of main batteries.
- **Consumer appliances** that have real-time clocks; provides switchover power from main supply to backup battery.
- **Business and industrial systems** such as: network routers, point-of-sale terminals, single-board computers, test equipment, multi-function printers, industrial controllers, and utility meters.
- **Energy Harvesting** by coupling the EnerChip with energy transducers such as solar panels.

During normal operation, the EnerChip CC charges itself with a controlled voltage using an internal charge pump that operates from 2.5V to 5.5V. An ENABLE pin allows for activation and deactivation of the charge pump using an external control line in order to minimize current consumption and take advantage of the fast recharge time of the EnerChip.

When the primary power supply dips below a user-defined threshold voltage, the EnerChip CC will signal this event and route the EnerChip voltage to VOUT. The EnerChip CC also has energy storage protection circuitry to enable thousands of recharge cycles.

The CBC3105-R4C is a 16-pin, 4mm x 5mm Dual Flat No-lead (DFN) package, available in tubes, trays, or tape-and-reel for use with automatic insertion equipment.

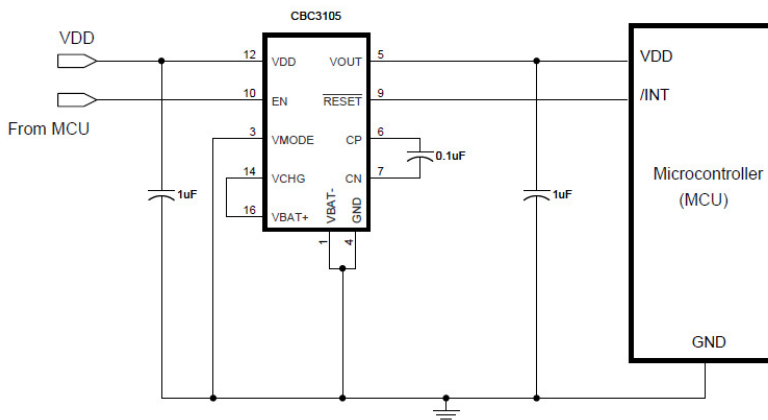

Figure 1: Typical EnerChip CC Application Circuit

Electrical Properties

EnerChip Backup Output voltage:	3.3V
Energy Capacity (typical):	5 μ Ah
Recharge time to 80%:	10 minutes
Charge/Discharge cycles:	>5000 to 10% discharge

Physical Properties

Package size:	4mm x 5mm
Operating temperature:	-20 °C to +70 °C
Storage temperature:	-40 °C to +125 °C

Functional Block Diagram

The EnerChip CC internal schematic is shown in Figure 2. The input voltage from the power supply (VDD) is applied to the charge pump, the control logic, and is compared to the user-set threshold as determined by the voltage on VMODE. VMODE is an analog input ranging from 0V to VDD. The ENABLE pin is a digital input that turns off the charge pump when low. VOUT is either supplied from VDD or the integrated EnerChip. RESET is a digital output that, when low, indicates VOUT is being sourced by the integrated EnerChip.

CFLY is the flying capacitor in the voltage doubler circuit. The value of CFLY can be changed if the output impedance of the EnerChip CC needs to be modified. The output impedance is dictated by $1/fC$, where f is the frequency of oscillation (typically 100kHz) and C is the capacitor value (typically 0.1 μ F). GND is system ground.

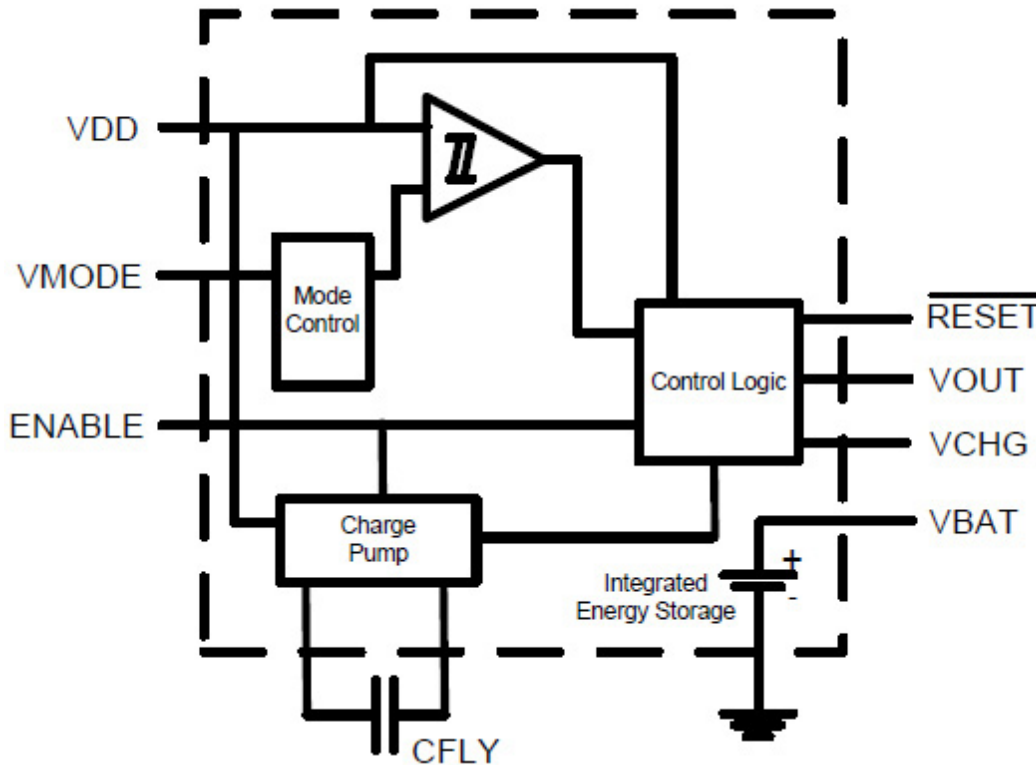

Figure 2: EnerChip CC CBC3105 Internal Block Diagram

CBC3105-R4C Input/Output Descriptions

Pin Number(s)	Label	Description
1	VBAT-	Negative EnerChip Terminal - Tie to System Ground
2	NC	No Connection
3	VMODE	Mode Select for Backup Switchover Threshold
4	GND	System Ground
5	VOUT	System Voltage
6	CP	Flying Capacitor Positive
7	CN	Flying Capacitor Negative
8	NC	No Connection
9	RESET	Reset Signal (Active Low)
10	ENABLE	Charge Pump Enable
11	NC	No Connection
12	VDD	Input Voltage
13	NC	No Connection
14	VCHG	EnerChip Charge Voltage - Tie to Pin 16 and/or Optional EnerChip(s)
15	NC	No Connection
16	VBAT+	Positive EnerChip Terminal - Tie to Pin 14

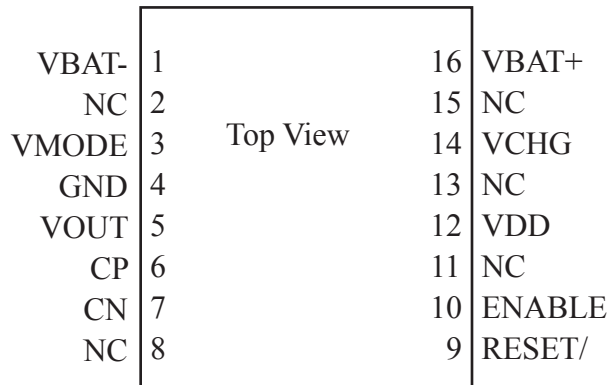

Figure 3: EnerChip CC CBC3105 Package Pin-Out

Absolute Maximum Ratings

PARAMETER	CONDITION	MIN	TYPICAL	MAX	UNITS
VDD with respect to GND	25 °C	GND - 0.3	-	6.0	V
ENABLE and VMODE Input Voltage	25 °C	GND - 0.3	-	VDD+0.3	V
VBAT ⁽¹⁾	25 °C	3.0	-	4.15	V
VCHG ⁽¹⁾	25 °C	3.0	-	4.15	V
VOUT	25 °C	GND - 0.3	-	6.0	V
RESET Output Voltage	25 °C	GND - 0.3	-	VOUT+0.3	V
CP, Flying Capacitor Voltage	25 °C	GND - 0.3	-	6.0	V
CN	25 °C	GND - 0.3	-	VDD+0.3	V

⁽¹⁾ No external connections to these pins are allowed, except parallel EnerChips.

Operating Characteristics

PARAMETER	CONDITION	MIN	TYPICAL	MAX	UNITS	
Output Voltage VOUT	VDD > VTH	-	VDD	-	V	
Output Voltage VOUT (backup mode)	VDD < VTH	2.2	3.3	3.6	V	
EnerChip Pulse Discharge Current	-	Variable - see App. Note 1025			-	
Self-Discharge (5 yr average)	Non-recoverable	-	2.5	-	% per year	
	Recoverable	-	1.5 ⁽¹⁾	-	% per year	
Operating Temperature	-	-20	25	+70	°C	
Storage Temperature	-	-40	-	+125 ⁽²⁾	°C	
Cell Resistance (25 °C)	Charge cycle 2	-	7	11	kΩ	
	Charge cycle 1000	-	31	48		
Recharge Cycles (to 80% of rated capacity; 4.1V charge voltage)	25 °C	10% depth-of-discharge	5000	-	-	cycles
		50% depth-of discharge	1000	-	-	cycles
	40 °C	10% depth-of-discharge	2500	-	-	cycles
		50% depth-of-discharge	500	-	-	cycles
Recharge Time (to 80% of rated capacity; 4.1V charge; 25 °C)	Charge cycle 2	-	11	22	minutes	
	Charge cycle 1000	-	45	70		
Capacity	40nA discharge; 25 °C	5	-	-	μAh	

⁽¹⁾ First month recoverable self-discharge is 5% average.

⁽²⁾ Storage temperature is for uncharged EnerChip CC device.

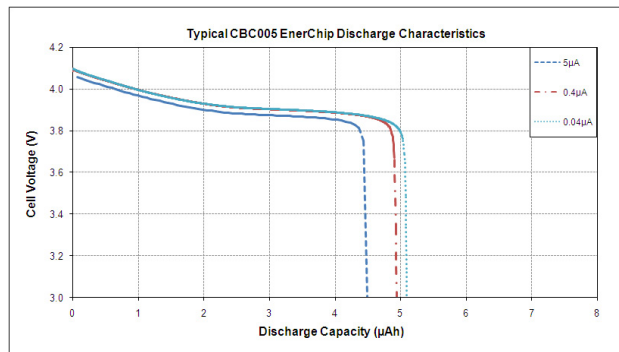
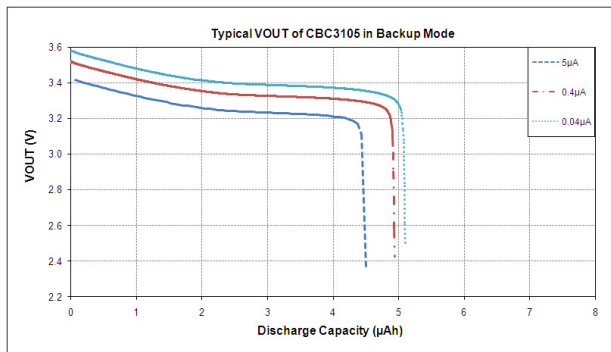

Note: All specifications contained within this document are subject to change without notice.

POWER SUPPLY CURRENT CHARACTERISTICS**Ta = -20°C to +70°C**

CHARACTERISTIC	SYMBOL	CONDITION	MIN	MAX	UNITS	
Quiescent Current	I _Q	ENABLE=GND	V _{DD} =3.3V	-	3.5	μA
			V _{DD} =5.5V	-	6.0	μA
		ENABLE=V _{DD}	V _{DD} =3.3V	-	35	μA
			V _{DD} =5.5V	-	38	μA
EnerChip Cutoff Current	I _{QBATOFF}	V _{BAT} < V _{BATCO} , V _{OUT} =0	-	0.5	nA	
	I _{QBATON}	V _{BAT} > V _{BATCO} , ENABLE=V _{DD} , I _{OUT} =0	-	42	nA	

INTERFACE LOGIC SIGNAL CHARACTERISTICS**V_{DD} = 2.5V to 5.5V, Ta = -20°C to +70°C**

CHARACTERISTIC	SYMBOL	CONDITION	MIN	MAX	UNITS
High Level Input Voltage	V _{IH}	-	V _{DD} - 0.5	-	Volts
Low Level Input Voltage	V _{IL}	-	-	0.5	Volts
High Level Output Voltage	V _{OH}	V _{DD} > V _{TH} (see Figures 4 and 5) I _L =10μA	V _{DD} - 0.04V ⁽¹⁾	-	Volts
Low Level Output Voltage	V _{OL}	I _L = -100μA	-	0.3	Volts
Logic Input Leakage Current	I _{IN}	0 < V _{IN} < V _{DD}	-1.0	+1.0	nA

⁽¹⁾ *RESET* tracks V_{DD}; *RESET* = V_{DD} - (I_{OUT} x R_{OUT}).**RESET SIGNAL AC/DC CHARACTERISTICS****V_{DD} = 2.5V to 5.5V, Ta = -20°C to +70°C**

CHARACTERISTIC	SYMBOL	CONDITION	MIN	MAX	UNITS
V _{DD} Rising to $\overline{\text{RESET}}$ Rising	t _{RESETH}	V _{DD} rising from 2.8V TO 3.1V in <10μs	60	200	ms
V _{DD} Falling to $\overline{\text{RESET}}$ Falling	t _{RESETL}	V _{DD} falling from 3.1V to 2.8V in <100ns	0.5	2	μs
Mode 1 TRIP V V _{DD} Rising	V _{RESET}	V _{MODE} =GND	2.85	3.15	V
Mode 2 TRIP V ⁽²⁾ V _{DD} Rising	V _{RESET}	V _{MODE} = V _{DD} /2	2.40	2.60	V
$\overline{\text{RESET}}$ Hysteresis Voltage ⁽³⁾ (V _{DD} to $\overline{\text{RESET}}$)	V _{HYST}	V _{MODE} =V _{DD}	60	100	mV
		V _{MODE} =GND	45	75	
		V _{MODE} = V _{DD} /2	30	50	

⁽²⁾ User-selectable trip voltage can be set by placing a resistor divider from the V_{MODE} pin to GND. Refer to Figure 8.⁽³⁾ The hysteresis is a function of trip level in Mode 2. Refer to Figure 9.

CHARGE PUMP CHARACTERISTICS**V_{DD} = 2.5V to 5.5V, T_a = -20°C to +70°C**

CHARACTERISTIC	SYMBOL	CONDITION	MIN	MAX	UNITS
ENABLE=V _{DD} to Charge Pump Active	t _{CPON}	ENABLE to 3rd charge pump pulse, V _{DD} =3.3V	60	80	μs
ENABLE Falling to Charge Pump Inactive	t _{CPOFF}	-	0	1	μs
Charge Pump Frequency	f _{CP}		-	120	KHz ⁽¹⁾
Charge Pump Resistance	R _{CP}	Delta V _{BAT} , for I _{BAT} charging current of 1μA to 100μA C _{FLY} =0.1μF, C _{BAT} =1.0μF	150	300	Ω
V _{CHG} Output Voltage	V _{CP}	C _{FLY} =0.1μF, C _{BAT} =1.0μF, I _{OUT} =1μA, Temp=+25°C	4.075	4.125	V
V _{CHG} Temp. Coefficient	T _{CCP}	I _{OUT} =1μA, Temp=+25°C	-2.0	-2.4	mV/°C
Charge Pump Current Drive	I _{CP}	I _{BAT} =1mA C _{FLY} =0.1μF, C _{BAT} =1.0μF	1.0	-	mA
Charge Pump on Voltage	V _{ENABLE}	ENABLE=V _{DD}	2.5	-	V

⁽¹⁾ $f_{CP} = 1/t_{CPPER}$ **ADDITIONAL CHARACTERISTICS****T_a = -20°C to +70°C**

CHARACTERISTIC	SYMBOL	CONDITION	LIMITS		UNITS
			MIN	MAX	
V _{BAT} Cutoff Threshold	V _{BATCO}	I _{OUT} =1μA	2.75	3.25	V
Cutoff Temp. Coefficient	T _{CCO}	-	+1	+2	mV/°C
V _{BAT} Cutoff Delay Time	t _{COOFF}	V _{BAT} from 40mV above to 20mV below V _{BATCO} I _{OUT} =1μA	40	-	ms
V _{OUT} Dead Time, V _{DD} Rising ⁽²⁾	t _{RSBR}	I _{OUT} =1mA V _{BAT} =4.1V	0.2	2.0	μs
V _{OUT} Dead Time, V _{DD} Falling ⁽²⁾	t _{RSBF}	V _{BAT} =4.1V	0.2	2.0	μs
Bypass Resistance	R _{OUT}	-	-	2.5	Ω

⁽²⁾ Dead time is the time period when the V_{OUT} pin is floating. Size the holding capacitor accordingly.**Note: All specifications contained within this document are subject to change without notice**

Important timing diagrams for the EnerChip CC relationship between EnerChip Switchover Timing and EnerChip Disconnect from Load Timing are shown in Figure 4.

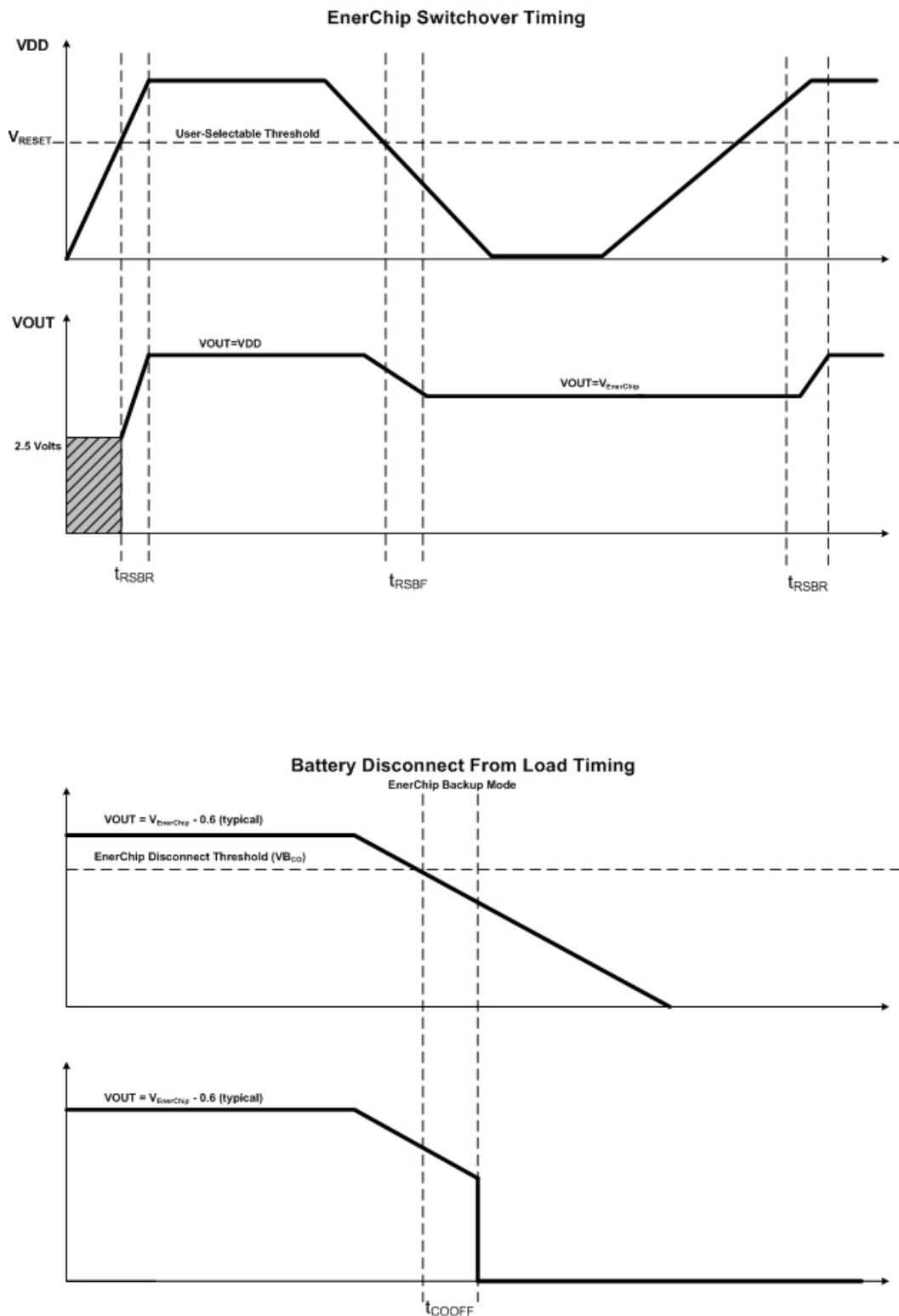

Figure 4: EnerChip CC Switchover and Disconnect Timing Diagrams

Timing diagrams for the EnerChip CC relationship between VDD to $\overline{\text{RESET}}$ and ENABLE high to charge pump becoming active are shown in Figure 5.

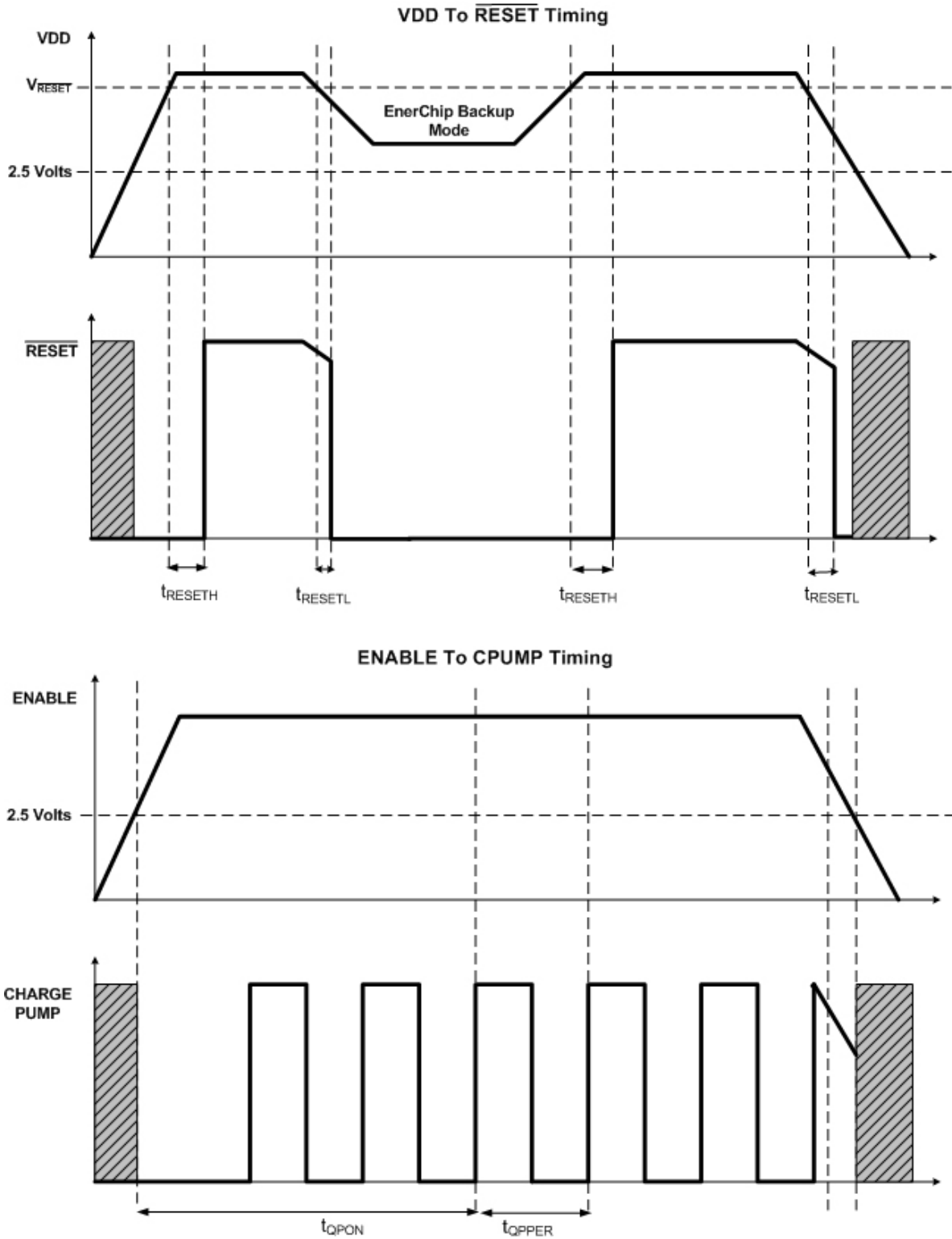

Figure 5: Timing Diagrams for VDD to $\overline{\text{RESET}}$ and Enable to Charge Pump Active.

EnerChip CC Detailed Description

The EnerChip CC uses a charge pump to generate the supply voltage for charging the integrated energy storage device. An internal FET switch with low $R_{DS(on)}$ is used to route V_{DD} to V_{OUT} during normal operation when main power is above the switchover threshold voltage. When V_{DD} is below the switchover threshold voltage, the FET switch is shut off and V_{OUT} is supplied by the EnerChip. An interrupt signal is asserted low prior to the switchover.

Operating Modes

The EnerChip CC can be operated from various power supplies such as a primary source or a non-rechargeable battery. With the ENABLE pin asserted high, the charge pump is active and charges the integrated EnerChip. The EnerChip CC will be 80% charged within 10 minutes. Due to the rapid recharge it is recommended that, once the EnerChip CC is fully charged, the user de-assert the ENABLE pin (i.e., force low) to reduce power consumption. A signal generated from the MCU could be used to enable and disable the EnerChip CC.

When controlling the ENABLE pin by way of an external controller - as opposed to fixing the ENABLE line to VDD - ensure that the ENABLE pin is forced low by the controller anytime the \overline{RESET} line is low, which occurs when the switchover threshold voltage is reached and the device is placed in backup mode. Although the internal charge pump is designed to operate below the threshold switchover level when the ENABLE line is active, it is recommended that the ENABLE pin be forced low whenever \overline{RESET} is low to ensure no parasitic loads are placed on the EnerChip while in this mode. If ENABLE is high or floating while VDD is in an indeterminate state, bias currents within the EnerChip CC could flow, placing a parasitic load on the EnerChip that could dramatically reduce the effective backup operating time.

The EnerChip CC supports 2 operational modes as shown in Figures 6 and 7.

Mode 1 Operation

For use in 3.3 volt systems. The V_{MODE} pin should be tied directly to GND, as shown in Figure 6. This will set the switchover threshold at approximately 3.0 volts.

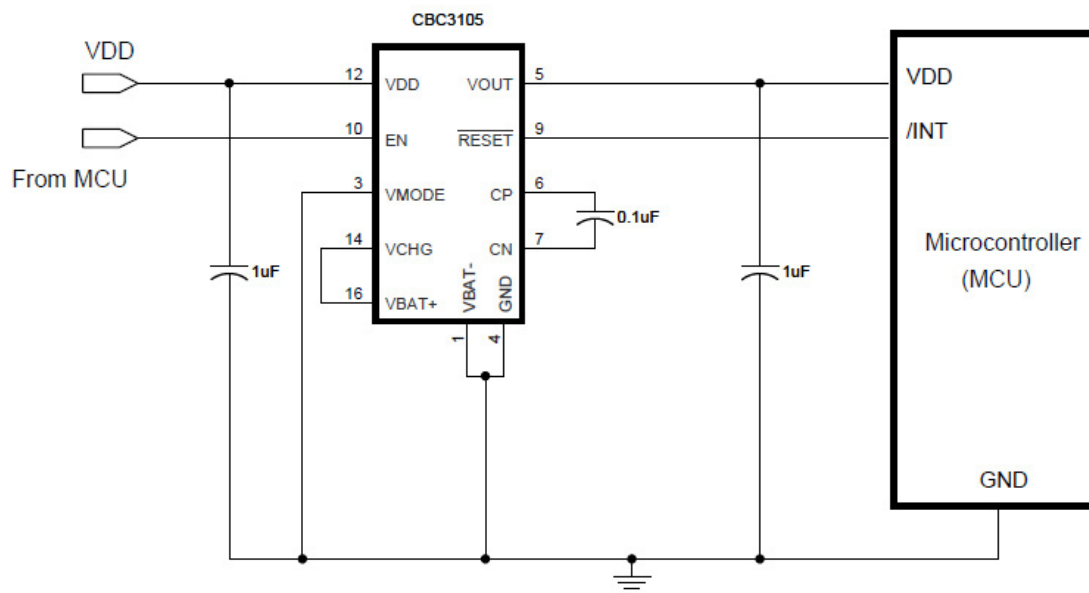

Figure 6: CBC3105 Typical Circuit for Mode 1 Operation

Mode 2 Operation

Figure 7 shows the circuitry for user-selectable switchover threshold to a value between 2.5 and 5.0 volts. Use Figure 8 to determine the value of R1. To determine the amount of hysteresis from the EnerChip switchover threshold, use Figure 9.

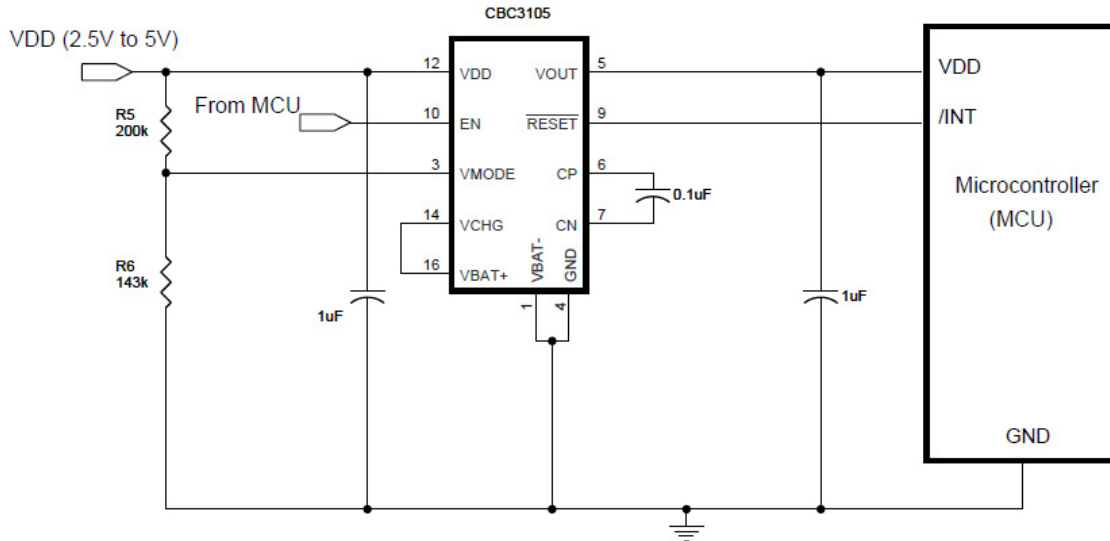

Figure 7: CBC3105 Typical Circuit for Mode 2 Operation

EnerChip charging and backup power switchover threshold for 2.5 to 5.5 volt operation is selected by changing the value of R2 (see Figure 7). To determine the backup switchover point, set the value of R1 to 200kΩ and choose the value of R2 according to Figure 8. For example, to set a 3.0V trip point: If R1=200 kΩ then R2 = R1 x 0.72 = 144kΩ. Figure 7 shows a Mode 2 circuit with standard value resistors of 200kΩ and 143kΩ.

To determine the backup switchover hysteresis for Mode 2 operation, use Figure 9.

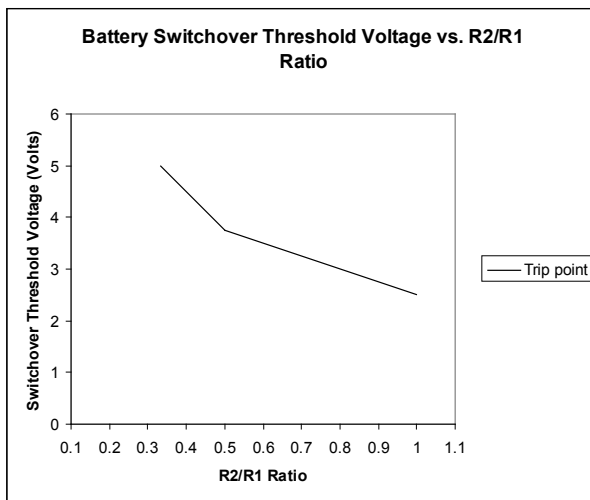

Figure 8: Mode 2 Resistor Selection Graph

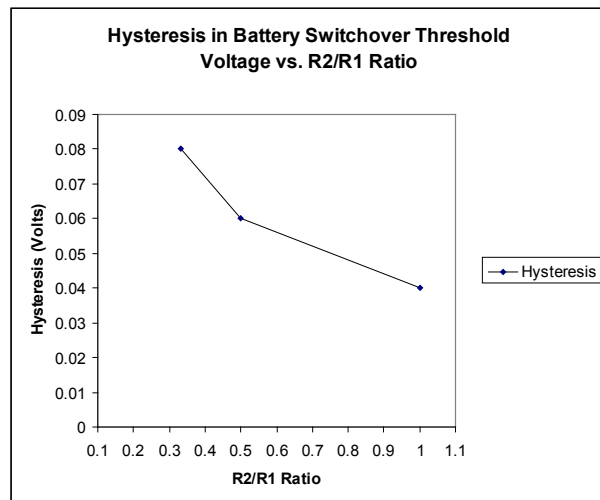

Figure 9: Mode 2 Hysteresis as a Function of R2/R1

Real-Time Clock Application Circuit

The EnerChip CC as depicted in Figure 10 is a typical application circuit in a 3.3 volt system where backup and power switchover circuitry for a real-time clock device is provided.

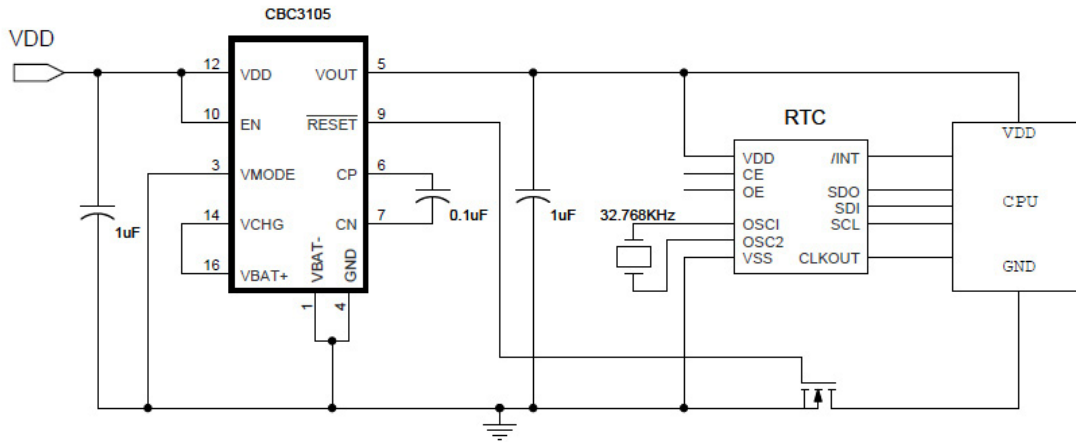

Figure 10: EnerChip CC Providing Backup Power for RTC with SPI Bus

CBC3105-R4C Evaluation Board

The CBC3105-R4C evaluation board as shown in the photo and schematic below is included in the CBC-EVAL-05B EnerChip CC Evaluation Kit. This board is 16 pins in the same 24-pin DIP configuration as the EVAL-05 CBC3150/CBC3112 eval board. This eval board is easy to use with proto-boards or sockets for design evaluation.

Note that the Enerchip CBC3105 is shipped in a charged state and it is advised to not solder the CBC3105 evaluation board to another board as the high temperatures of a manual soldering process are outside the CBC3105 operating specifications.

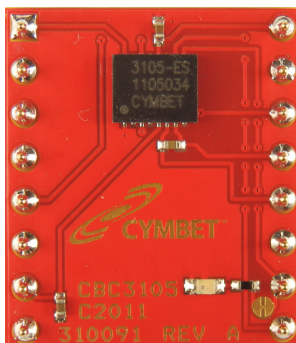

Figure 11: CBC3105-R4C Evaluation Board

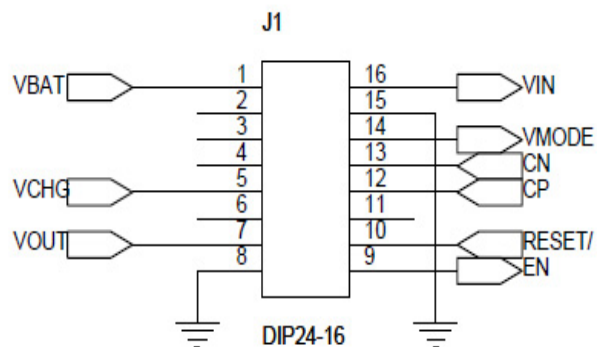
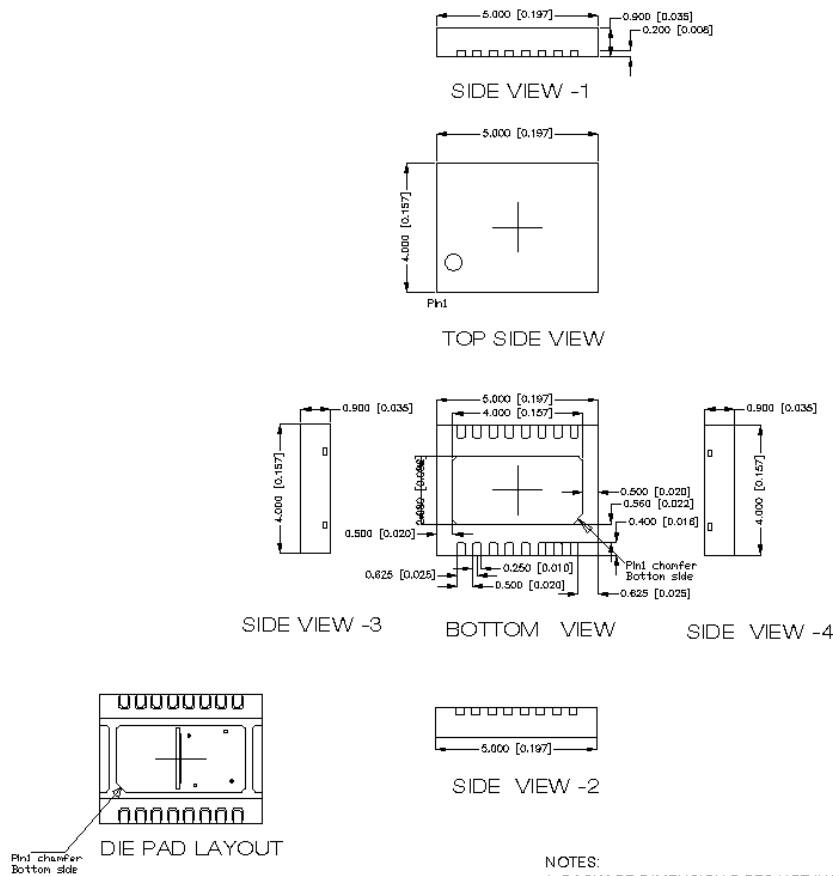

Figure 12: CBC3105-R4C Eval Board Pin-out

CBC3105-R4C 4mm x 5mm x 0.9mm DFN Package Drawing



- NOTES:
1. PACKAGE DIMENSION DOES NOT INCLUDE MOLD FLASH, PROTRUSIONS, BURRS OR METAL SMEARING.
 2. COPLANARITY APPLIES TO THE EXPOSED PAD AS WELL AS THE EXPOSED TERMINALS.
MAXIMUM COPLANARITY SHALL BE 0.003 [0.08].
 3. WARPAGE SHALL NOT EXCEED 0.004 [0.10].
 4. REFER TO JEDEC MO-229 OUTLINE.
 5. EXPOSED METALLIZED FEATURE CONNECTED TO DIE PADDLE.

Dimensions in mm [inches].

Ordering Information

EnerChip CC Part Number	Description	Notes
CBC3105-R4C	EnerChip CC 5µAh in 16-pin DFN	Shipped in Tube
CBC3105-R4C-TR1 CBC3105-R4C-TR5	EnerChip CC 5µAh in 16-pin DFN	Tape-and-Reel - 1000 pcs (TR1) or 5000 pcs (TR5) per reel
CBC3105-R4C-WP	EnerChip CC 5µAh in 16-pin DFN	Waffle Pack
CBC-EVAL-05B	EnerChip CC Eval Kit	Contains CBC3105 Eval Board

U.S. Patent No. 8,144,508. Additional U.S. and Foreign Patents Pending

Disclaimer of Warranties; As Is

The information provided in this data sheet is provided "As Is" and Cymbet Corporation disclaims all representations or warranties of any kind, express or implied, relating to this data sheet and the Cymbet EnerChip product described herein, including without limitation, the implied warranties of merchantability, fitness for a particular purpose, non-infringement, title, or any warranties arising out of course of dealing, course of performance, or usage of trade. Cymbet EnerChip products are not authorized for use in life critical applications. Users shall confirm suitability of the Cymbet EnerChip product in any products or applications in which the Cymbet EnerChip product is adopted for use and are solely responsible for all legal, regulatory, and safety-related requirements concerning their products and applications and any use of the Cymbet EnerChip product described herein in any such product or applications.

Cymbet, the Cymbet Logo, and EnerChip are Cymbet Corporation Trademarks