

EXCEED Light-emitting diode

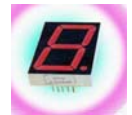

Specification For Approval

Customer: _____

Description: LED-LAMP

Part number: RL30-HO3YG439T1

Date: 2004/11/25

Approved By:

Prepared By:

Approval	Check	Design	Sales

EXCEED PERSEVERANCE ELECTRONICS IND CO., LTD

www.exceedledcn.com

EXCEED

Light-emitting diode



PartNumber: RL30-HO3YG439T1

Features

- 1.Low power consumption .
- 2.High efficiency.
- 3.Versatile mounting on p.c board or panel.
- 4.I.C compatible/ low current requirement.

★Package Dimensions

Unit: mm

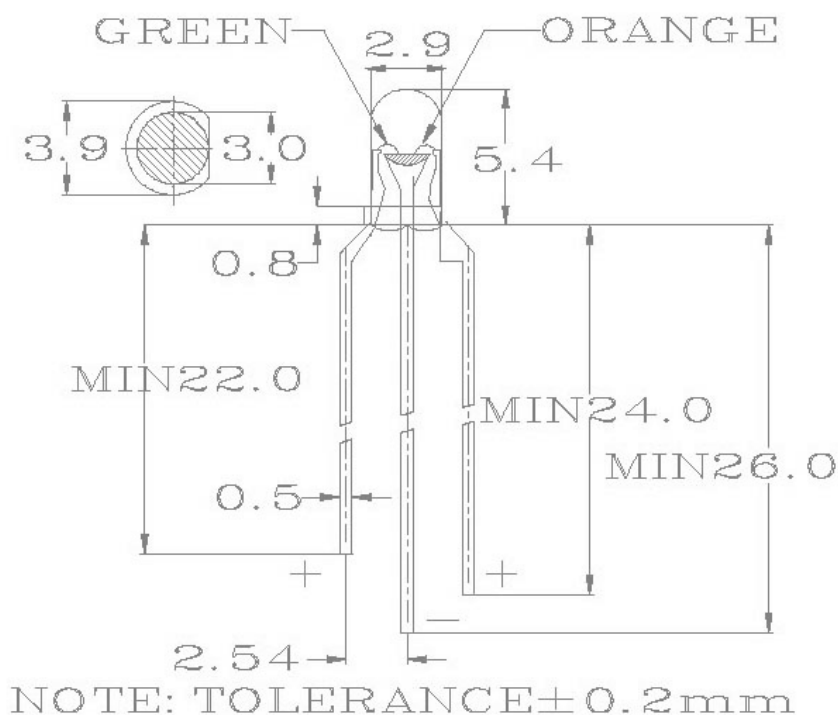

★ Selection Guide

Part Number	Lens color	Chip		
		Material	Emitted color	λ p(nm)
RL30-HO3YG439T1	Diffuse	GaAsP/GaP	RED ORANGE	630
		GaP/GaP	GREEN	570

EXCEED PERSEVERANCE ELECTRONICS IND CO.. LTD.

EXCEED

Light-emitting diode



TECHNICAL SPECIFICATION

Part Number: RL30-HO3YG439T1(RED ORANGE)

Parameter	Symbol	MIN.	TYP.	MAX.	UNIT	TEST CONDITION
Forward Voltage	VF	1.7	2.0	2.8	V	If=20mA
Peak Wavelength	λ_p	625	630	635	nm	
Reverse Current	IR			40	μ A	VR=5V
Power dissipation	Pd			85	mW	
Luminous Intensity	IV	29	56		mcd	If=20mA
Peak Forward Current	If(Peak)			160	mA	
Recommend Forward Current	If(Rec)		10		mA	
Full Viewing Angle	$2\theta_{1/2}$		50		deg	If=20mA

NOTE:

1.Luminous intensity is measured with a light sensor and fillister combination that approximates the CIE eye-response curve Tester: EG&G DR-2550.

2.IV classification code is marked on each packing bag. The IV base on line-on's bin classification. The IV guarantee should be add $\pm 15\%$

3.Absolute maximum ratings: (Ta=25°C)

4.Operating temperature : -40°C TO 80°C

5.Lead soldering: 260°C for 5 seconds

EXCEED Light-emitting diode

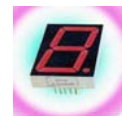

Part Number: **RL30-HO3YG439T1**

Red Orange

Fig1. Forward Current vs Forward Voltage

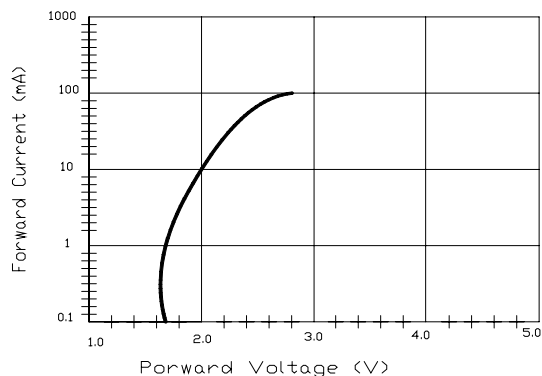

Fig2. Relative Intensity vs Forward Current

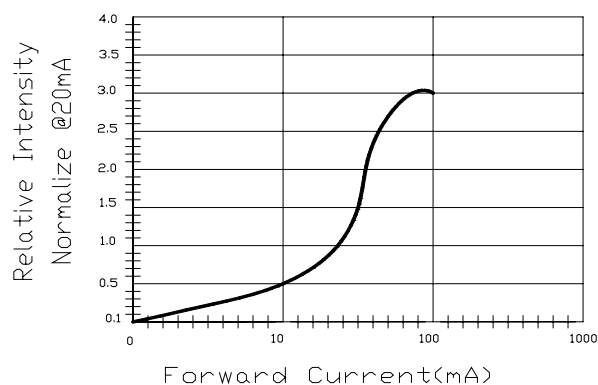

Fig3. Forward Voltage vs Temperature

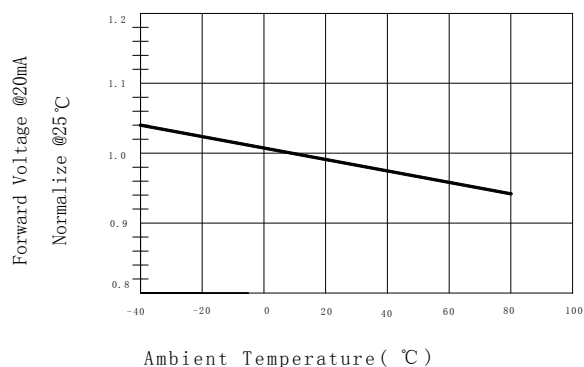

Fig4. Relative Intensity vs Temperature

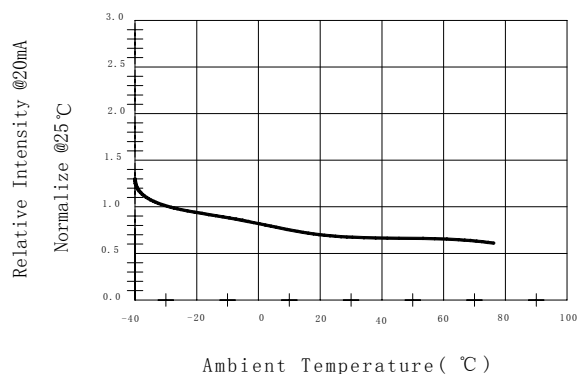

Fig5. Relative Intensity vs Wavelength

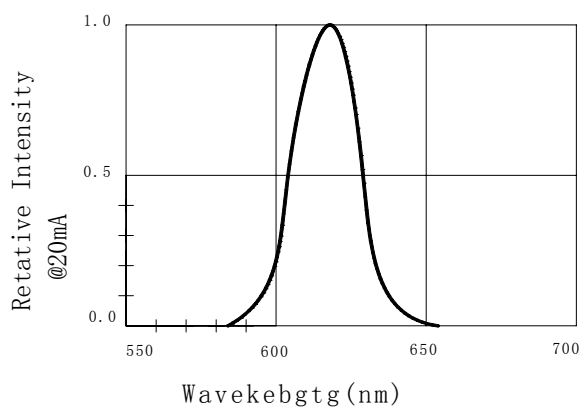
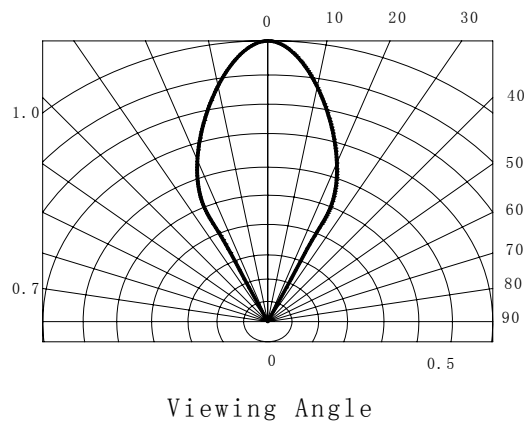

Fig6. Viewing Angle



EXCEED

Light-emitting diode



TECHNICAL SPECIFICATION

Part Number: RL30-HO3YG439T1(GREEN)

Parameter	Symbol	MIN.	TYP.	MAX.	UNIT	TEST CONDITION
Forward Voltage	VF	1.7	2.1	2.8	V	If=20mA
Peak Wavelength	λ_p	568	570	573	nm	
Reverse Current	IR			40	μ A	VR=5V
Power dissipation	Pd			120	mW	
Luminous Intensity	IV	28	55		mcd	If=20mA
Peak Forward Current	If(Peak)			160	mA	
Recommend Forward Current	If(Rec)		10-20		mA	
Full Viewing Angle	$2\theta_{1/2}$		50		deg	If=20mA

NOTE:

1.Luminous intensity is measured with a light sensor and fillister combination that approximates the CIE eye-response curve Tester: EG&G DR-2550.

2.IV classification code is marked on each packing bag. The IV base on line-on's bin classification. The IV guarantee should be add $\pm 15\%$

3.Absolute maximum ratings: (Ta=25°C)

4.Operating temperature : -40°C TO 80°C

5.Lead soldering: 260°C for 5 seconds

EXCEED Light-emitting diode



Part Number: **RL30-HO3YG439T1**

Green

Fig1. Forward Current vs Forward Voltage

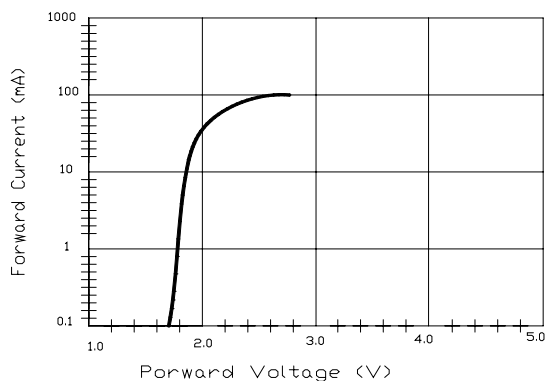

Fig2. Relative Intensity vs Forward Current

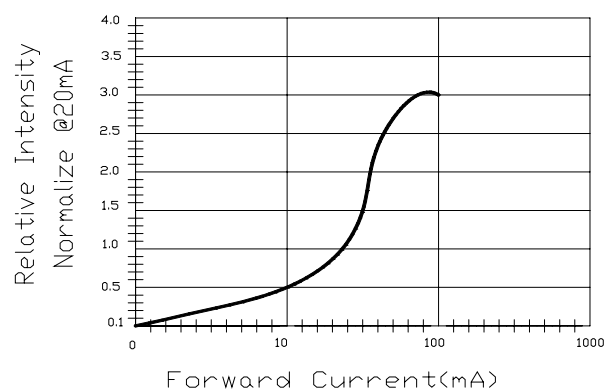

Fig3. Forward Voltage vs Temperature

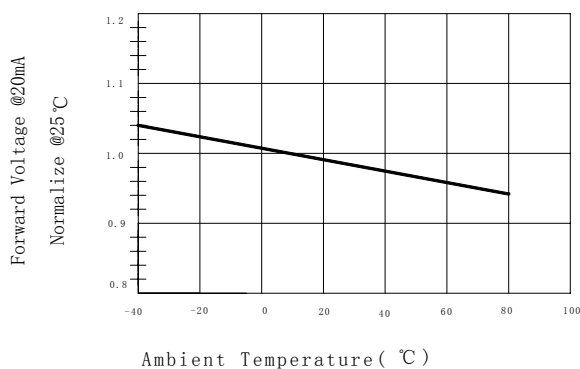

Fig4. Relative Intensity vs Temperature

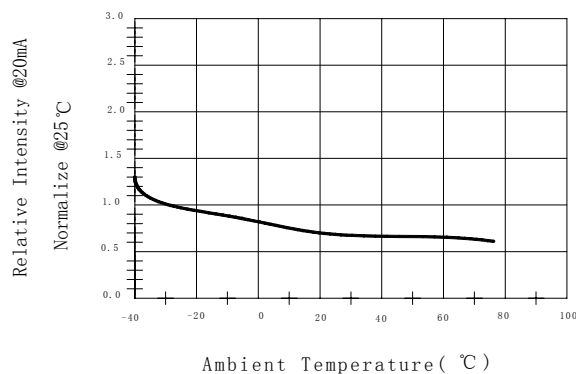

Fig5. Relative Intensity vs Wavelength

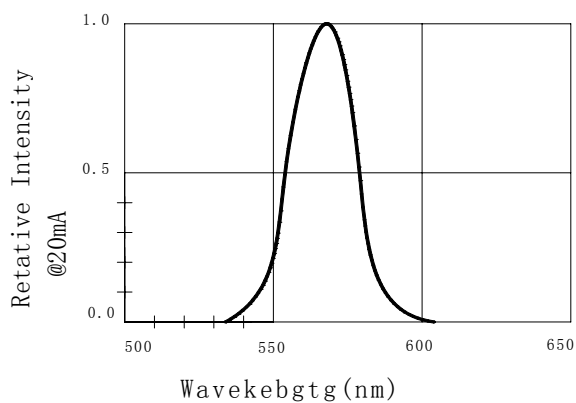

Fig6. Viewing Angle

