

Gas Sensor General Measuring Circuit
MQ series gas sensor

Parts	Materials
1 Gas sensing layer	SnO ₂
2 Electrode	Au
3 Electrode line	Pt
4 Heater coil	Ni-Cr alloy
5 Tubular ceramic	Al ₂ O ₃
6 Anti-explosion network	Stainless steel gauze (SUS316 100-mesh)
7 Clamp ring	Copper plating Ni
8 Resin base	Bakelite
9 Tube Pin	Copper plating Ni

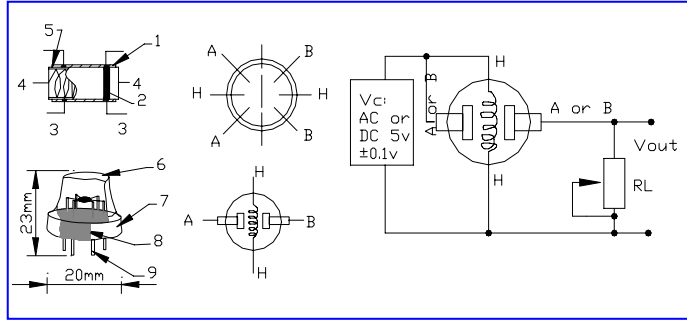

MQ200 series gas sensor

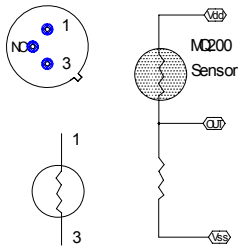

MQ300 series gas sensor

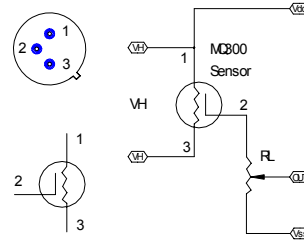

MC/MR series gas sensor

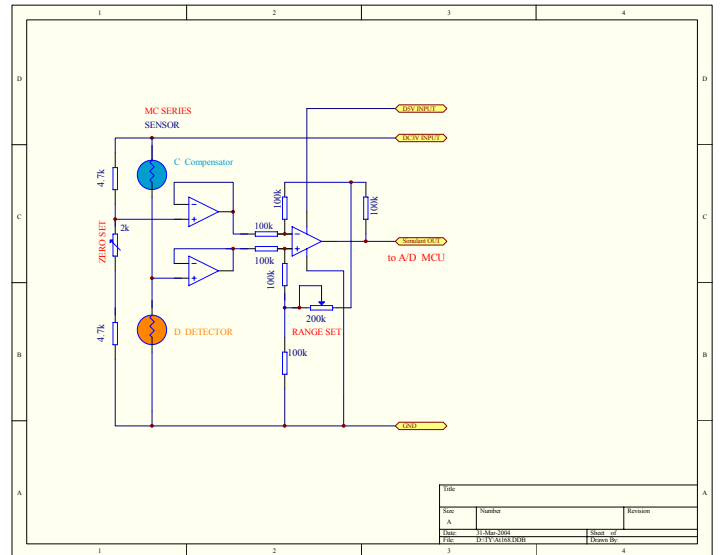
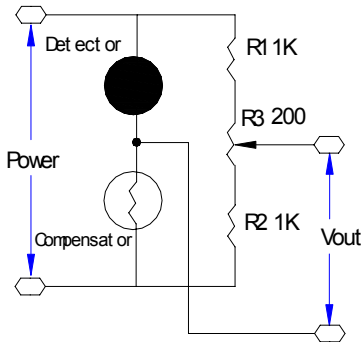

Gas Detector Reference Circuit

