

MQ309A

for CARBON MONOXIDE(CO) and Methane Detection

General Information

MQ309A is a tin dioxide semiconductor gas sensor which has excellent performance in detecting both CO and Methane. It is miniature sensor adopt changing working temperature periodically to detect with high sensitivity and selectivity, the humidity has little influence on it.

Configuration

Gas sensor sensitivity material is a mini bead, a heater coil and electrode wire are embedded in the element, this element is installed in the in the metal housing which uses double stainless steel mesh(100mesh) with anti-explosion function. (As figure1)

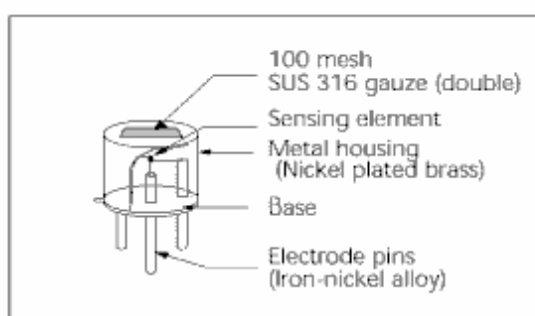

Fig 1a. Configuration

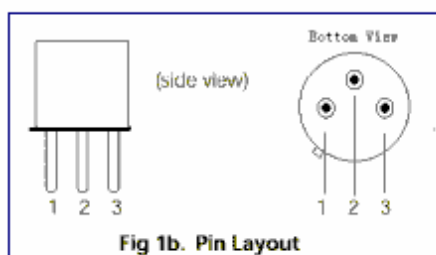

Fig 1b. Pin Layout

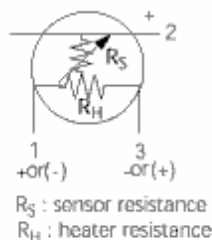
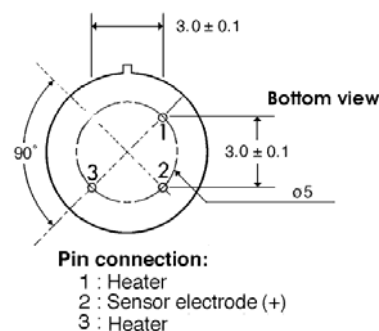
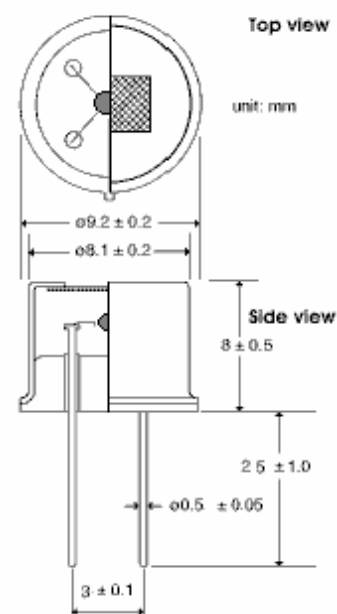

Fig 1c. Equivalent circuit

Structure and Dimensions:



Operating conditions

When the gas sensor is operated with high/low periodic operation (As figure 2), sensor signal changes according to its temperature dependency. By detecting the sensors signal at sufficient timings (at high temperature for methane and at a low temperature for CO), selective detection of both methane and CO has been achieved. Figs 3 and 3b show the sensitivity characteristics of the MQ309A, at high temperature and at low temperature signals respectively.

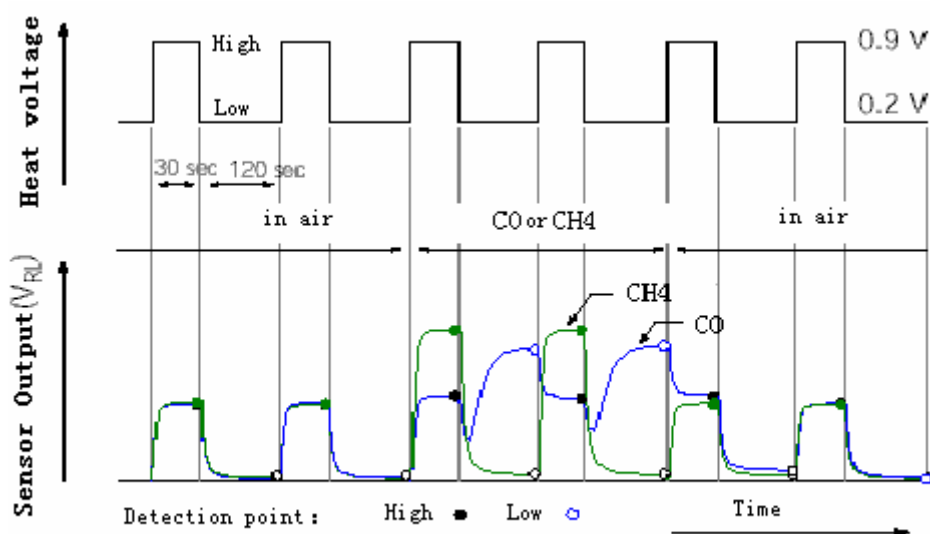

Fig2 MQ309A Operating conditions and output signal

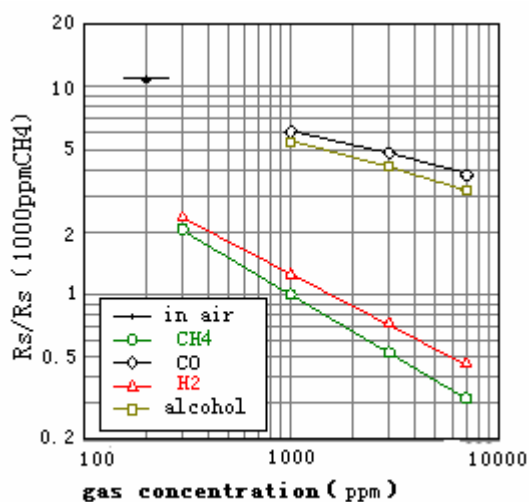

Fig3 sensitivity at high signal for methane

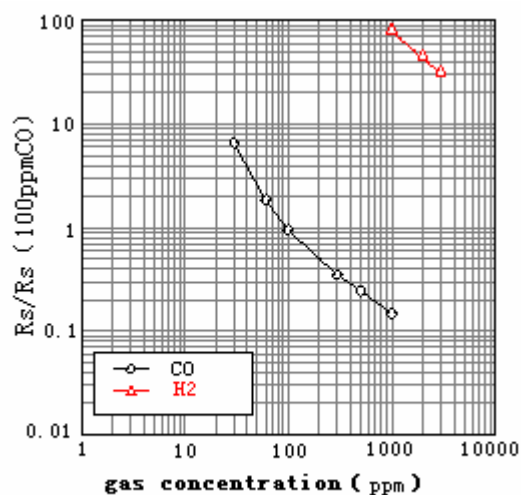

Fig 4 sensitivity at low signal for CO

A. Standard working conditions

Symbol	Paramant	Specifications	Remarks
VH(H)	Heater voltage (high)	0.9V ± 0.10V	AC or DC
VH(L)	Heater voltage (Low)	0.2 V ± 5%	DC (polarity is important)
V _C	Circuit Voltage	≤ 6 V	
R _L	Load resistance	Adjustable (> 10 KΩ)	P S < 10 mW
R _H	Heater Resistance	4.0 Ω ± 1.0 Ω	At room temperature
TH(H)	Heating time (hihg)	30sec ± 5 sec	
TH(L)	Heating time (low)	120 sec ± 10sec	
DT(L)	Detecting time (low)	< 1 sec	Before switching to Low
I(H)	Current consumption (high)	≤80mA	VH=0.9V

I(L)	Current Consumption (low)	40±5mW	VH=0.2V
P _s	Power siddipation	≤10 mW	$P S = (V C - V R L) ^ 2 / R s$

B. Environmental Conditions

Symbol	Parameter	Specification	Remarks
Tao	Operating Temperature	-20 ° C...+50 ° C	Recommended range
Tas	Storage temperature	-20 ° C...+70 ° C	
RH	Relative Humidity	≤ 95% RH	
(O ₂)	Oxygen Concentration	21%±1%(Standard Terms) The sensitivity character are influenced by the variation in OXYGEN concentration	Absolute Minimum Level: more than18%

C. Sensitivity

Mosel	MQ-309		
Symbol	Parameter	Specifications	Remarks
R _s	Sensor resistance at low period	(20kΩ to 200 kΩ)	In 200 ppm CO
α (100-300)	Sensitivity Slope(30-100PPM)	1.05 to 2.1	Rs (300 ppmCO) / Rs (100 ppmCO)
α (3000-5000)	Sensitivity slope at Low	0.75 to 1.2	Rs(5000 ppmCH ₄) /Rs(3000ppmCH ₄)
Standard test Conditions : Temperature: 20 ° C ± 2 ° C V C : 5.0 V ± 1% Humidity: 65% ± 5% V H : 0.9 V ± 1% R L : 50K Ω ±5% Preheating time : more than 48 hours			

HANWEI ELETRONICS CO.,LTD

TEL:+86-371-8732420 8732424 6953352

FAX:+86-371-8730444 6962121

Email:sensor@371.net <http://www.hwsensor.com>