

# TECHNICAL DATA

# MQ-131 GAS SENSOR

## FEATURES

- Fast response and High sensitivity
- Stable and long life
- Simple drive circuit
- Wide detecting range

## APPLICATION

They are used in air quality control equipments for buildings/offices, are suitable for detecting of O<sub>3</sub>.

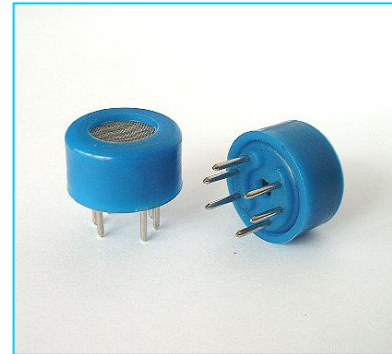

## SPECIFICATIONS

### A. Standard work condition

Symbol	Parameter name	Technical condition	Remarks
V <sub>c</sub>	Circuit voltage	5V±0.1	AC or DC
V <sub>H</sub>	Heating voltage	6V±0.1	AC or DC
R <sub>L</sub>	Load resistance	Variable	
R <sub>H</sub>	Heater resistance	31Ω ±5%	Room Tem
P <sub>H</sub>	Heating consumption	Less than 1100mw	

### B. Environment condition

Symbol	Parameter name	Technical condition	Remarks
T <sub>ao</sub>	Using Tem	-10℃...+50℃	
T <sub>as</sub>	Storage Tem	-20℃...+70℃	
R <sub>H</sub>	Related humidity	Less than 95%RH	

### C. Sensitivity characteristic

Symbol	Parameter name	Technical parameter	Remark 2
R <sub>s</sub>	Sensing Resistance	100KΩ -200KΩ (50ppb O <sub>3</sub> )	Detecting concentration scope : 10ppb-2ppm O <sub>3</sub>
α O <sub>3</sub> (100ppb/50ppb)	Concentration Slope rate	≤ 0.65	
Standard Detecting Condition	Temp: 20℃ ±2℃ Humidity: 65%±5%	V <sub>c</sub> :5V±0.1 V <sub>H</sub> : 6V±0.1	
Preheat time	Over 24 hour		

### D. Structure and configuration, basic measuring circuit

Parts	Materials
1 Gas sensing layer	SnO <sub>2</sub>
2 Electrode	Au
3 Electrode line	Pt
4 Heater coil	Ni-Cr alloy
5 Tubular ceramic	Al <sub>2</sub> O <sub>3</sub>
6 Anti-explosion network	Stainless steel gauze (SUS316 100-mesh)
7 Clamp ring	Copper plating Ni
8 Resin base	Bakelite
9 Tube Pin	Copper plating Ni

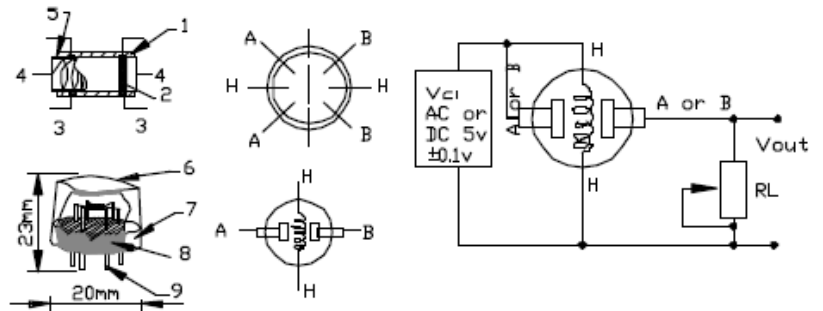
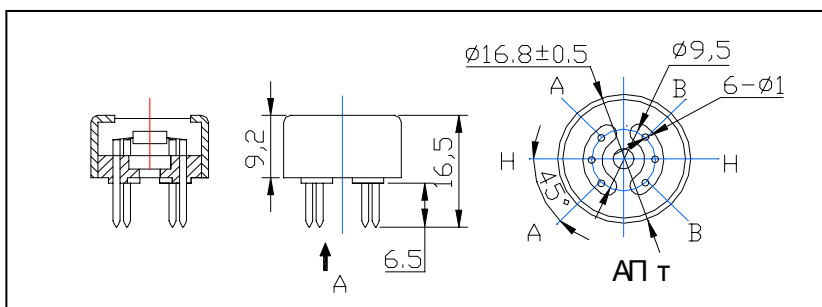

Fig. 1



Structure and configuration of MQ-131 gas sensor is shown as Fig.1, sensor composed by micro AL<sub>2</sub>O<sub>3</sub> ceramic tube, Metal-oxide semiconductor sensitive layer, measuring electrode and heater are fixed into a crust made by nylon and stainless steel net. The heater provides necessary work conditions for work of sensitive components. The enveloped MQ-131 have 6 pins ,4 of them are used to fetch signals, and other 2 are used for providing heating current.

Electric parameter measurement circuit is shown as above Fig.1.

**E. Sensitivity characteristic curve**

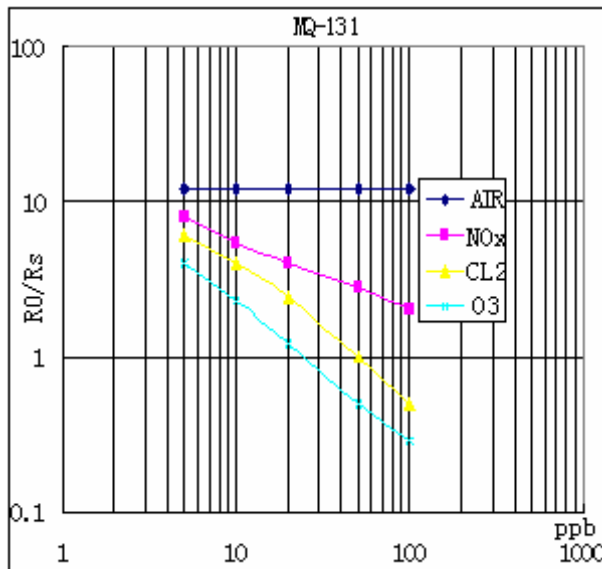

Fig.3 is shows the typical sensitivity characteristics of the MQ-131 for several gases.

in their: Temp: 20°C、  
Humidity: 65%、  
O<sub>2</sub> concentration 21%  
RL=20kΩ

R<sub>0</sub>: sensor resistance in the clean air.

R<sub>s</sub>: sensor resistance at various concentrations of gases.

Fig.3 sensitivity characteristics of the MQ-131

**APPLICATION**

Resistance value of MQ-131 is difference to various kinds and various concentration of gases. When using this components, sensitivity adjustment is very necessary. we recommend that you calibrate the detector for 50ppb O<sub>3</sub> in air and use value of Load resistance that( R<sub>L</sub>) about 100 KΩ (50KΩ to 200 KΩ ). When accurately measuring, the proper alarm point for the gas detector should be determined after considering the temperature and humidity influence.

Noting: there are a round hole in the up and down side of the sensors, this design enable the sensor inner gas to exchange better with outside air, and the sensor shall has higher sensitivity, quicker response and resume time with a fan.

**REFERENCE APPLICATION CIRCUIT:**

